

# Part III—Building Planning and Construction

## CHAPTER 3 BUILDING PLANNING

### SECTION R301 DESIGN CRITERIA

**R301.1 Application.** Buildings and structures, and all parts thereof, shall be constructed to safely support all loads, including dead loads, live loads, roof loads, flood loads, and wind loads as prescribed by this code. The construction of buildings and structures in accordance with the provisions of this code shall result in a system that provides a complete load path that meets all requirements for the transfer of all loads from their point of origin through the load-resisting elements to the foundation. Buildings and structures constructed as prescribed by this code are deemed to comply with the requirements of this section.

**Exception:** Buildings and structures located within the High Velocity Hurricane Zone shall comply with Sections R302 to R324, inclusive and the provisions of Chapter R44 and Section R406. In addition, buildings and structures located in flood hazard areas established in Table R301.2(1) shall comply with Sections R301.2.4 and R322.

**R301.1.1 Alternative provisions.** As an alternative to the requirements in Section R301.1 the following standards are permitted subject to the limitations of this code and the limitations therein. Where engineered design is used in conjunction with these standards, the design shall comply with the *Florida Building Code, Building*.

1. American Forest and Paper Association (AF&PA) *Wood Frame Construction Manual* (WFCM).
2. American Iron and Steel Institute (AISI) *Standard for Cold-Formed Steel Framing—Prescriptive Method for One- and Two-Family Dwellings* (AISI S230).
3. ICC-400 *Standard on the Design and Construction of Log Structures*.

**R301.1.2 Construction systems.** The requirements of this code are based on platform and balloon-frame construction for light-frame buildings. The requirements for concrete and masonry buildings are based on a balloon framing system. Other framing systems must have equivalent detailing to ensure force transfer, continuity and compatible deformations.

TABLE R301.2(1)  
CLIMATIC AND GEOGRAPHIC DESIGN CRITERIA

GROUND SNOW LOAD	WIND DESIGN		SEISMIC DESIGN CATEGORY <sup>f</sup>	SUBJECT TO DAMAGE FROM			WINTER DESIGN TEMP <sup>e</sup>	ICE BARRIER UNDERLAYMENT REQUIRED <sup>b</sup>	FLOOD HAZARDS <sup>g</sup>	AIR FREEZING INDEX <sup>i</sup>	MEAN ANNUAL TEMP <sup>j</sup>
	Speed <sup>d</sup> (mph)	Topographic effects <sup>k</sup> (NA)		Weathering <sup>a</sup>	Frost line depth <sup>b</sup>	Termite <sup>c</sup>					
NA	See Fig. R301.2(4)		NA	Negligible	NA	Very Heavy		NA		NA	NA

For SI: 1 pound per square foot = 0.0479 kPa, 1 mile per hour = 0.447 m/s.

- a. Weathering is “negligible” for concrete as determined from the Weathering Probability Map [Figure R301.2(3)]. The grade of masonry units shall be determined from ASTM C 34, C 55, C 62, C 73, C 90, C 129, C 145, C 216 or C 652.
- b. Reserved.
- c. Termite infestation per Figure R301.2(6) is “very heavy.”
- d. Wind speed shall be from the basic wind speed map [Figure R301.2(4)]. Wind exposure category shall be determined on a site-specific basis in accordance with Section R301.2.1.4.
- e. The outdoor design dry-bulb temperature shall be selected from the columns of 97<sup>1</sup>/<sub>2</sub>-percent values for winter from Appendix D of the *Florida Building Code, Plumbing*. Deviations from the Appendix D temperatures shall be permitted to reflect local climates or local weather experience as determined by the building official.
- f. Reserved.
- g. The applicable governing body shall, by local floodplain management ordinance, specify (a) the date of the jurisdiction’s entry into the National Flood Insurance Program (date of adoption of the first code or ordinance for management of flood hazard areas), (b) the date(s) of the Flood Insurance Study and (c) the panel numbers and dates of all currently effective FIRM and FBFM, or other flood hazard map adopted by the authority having jurisdiction, as amended.
- h. Reserved.
- i. Reserved.
- j. Reserved.
- k. Reserved.

**R301.1.3 Engineered design.** When a building of otherwise conventional construction contains structural elements exceeding the limits of Section R301 or otherwise not conforming to this code, these elements shall be designed in accordance with accepted engineering practice. The extent of such design need only demonstrate compliance of nonconventional elements with other applicable provisions and shall be compatible with the performance of the conventional framed system. Engineered design in accordance with the *Florida Building Code, Building* is permitted for all buildings and structures, and parts thereof, included in the scope of this code.

**R301.2 Climatic and geographic design criteria.** Buildings shall be constructed in accordance with the provisions of this code as limited by the provisions of this section. Additional criteria shall be set forth in Table R301.2(1).

**R301.2.1 Wind limitations.** Buildings and portions thereof shall be limited by wind speed, as defined in Table R301.2(1) and construction methods in accordance with this code. Basic

wind speeds shall be determined from Figure R301.2(4). Where different construction methods and structural materials are used for various portions of a building, the applicable requirements of this section for each portion shall apply. Where loads for wall coverings, curtain walls, roof coverings, exterior windows, skylights, and exterior doors (other than garage doors) are not otherwise specified, the loads listed in Table R301.2(2) adjusted for height and exposure using Table R301.2(3) shall be used to determine design load performance requirements for wall coverings, curtain walls, roof coverings, exterior windows, skylights and exterior doors (other than garage doors). Where loads for garage doors are not otherwise specified, the loads listed in Table R301.2(4) adjusted for height and exposure per Table R301.2(3), shall be used to determine design load performance requirements. Asphalt shingles shall be designed for wind speeds in accordance with Section R905.2.6.

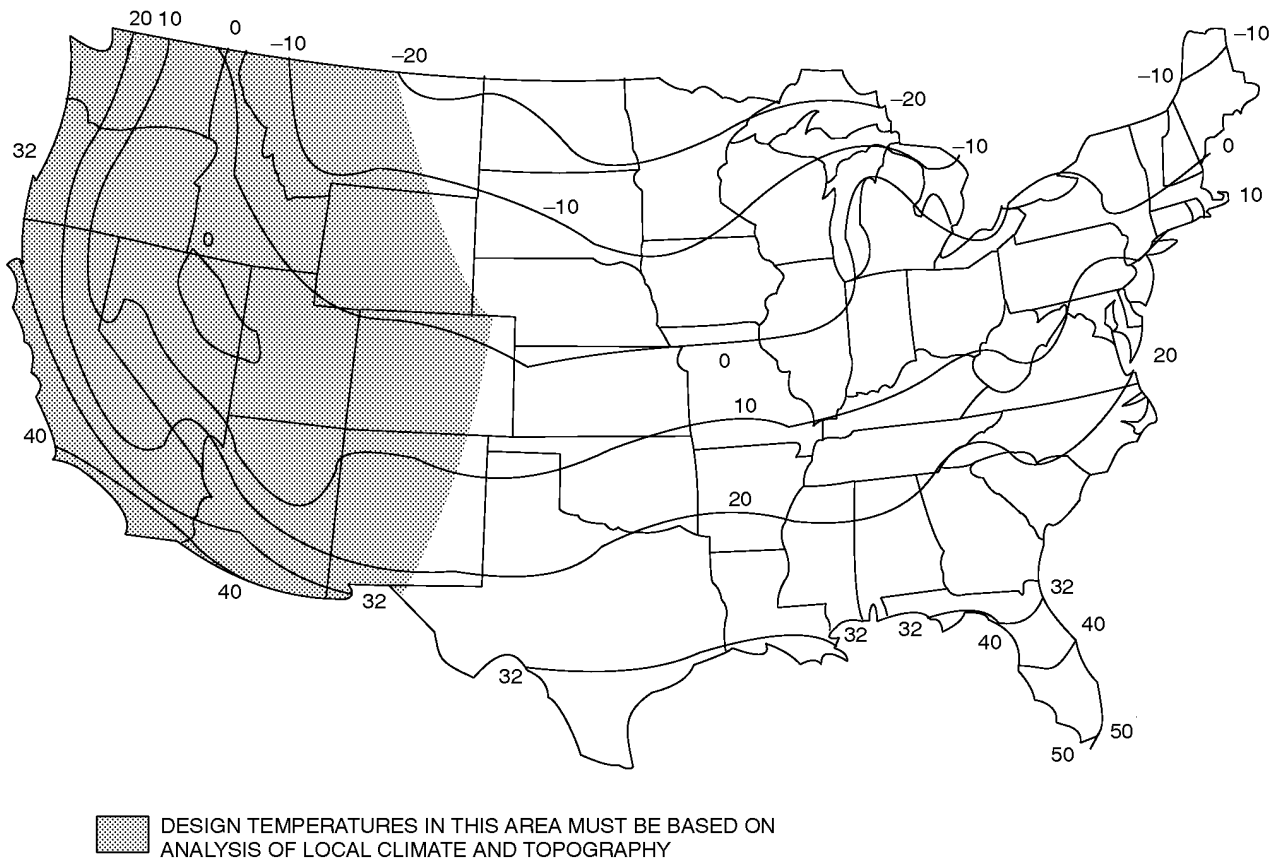

For SI: °C = [(°F)-32]/1.8.

**FIGURE R301.2(1)**  
**ISOLINES OF THE 97<sup>1</sup>/<sub>2</sub> PERCENT WINTER (DECEMBER, JANUARY AND FEBRUARY) DESIGN TEMPERATURES (°F)**

**TABLE R301.2(2)**  
**COMPONENT AND CLADDING LOADS FOR A BUILDING WITH A MEAN**  
**ROOF HEIGHT OF 30 FEET LOCATED IN EXPOSURE B (psf)<sup>a, b, c, d, e</sup>**

	ZONE	EFFECTIVE WIND AREA (feet <sup>2</sup> )	Ultimate Design Wind Speed $V_{ult}$ (mph)																	
			110		115		120		130		140		150		160		180		200	
Roof > 0 to 7 degrees	1	10	8.9	-21.8	9.7	-23.8	10.5	-25.9	12.4	-30.4	14.3	-35.3	16.5	-40.5	18.7	-46.1	23.7	-58.3	29.3	-72.0
	1	20	8.3	-21.2	9.1	-23.2	9.9	-25.2	11.6	-29.6	13.4	-34.4	15.4	-39.4	17.6	-44.9	22.2	-56.8	27.4	-70.1
	1	50	7.6	-20.5	8.3	-22.4	9.0	-24.4	10.6	-28.6	12.3	-33.2	14.1	-38.1	16.0	-43.3	20.3	-54.8	25.0	-67.7
	1	100	7.0	-19.9	7.7	-21.8	8.3	-23.7	9.8	-27.8	11.4	-32.3	13.0	-37.0	14.8	-42.1	18.8	-53.3	23.2	-65.9
	2	10	8.9	-36.5	9.7	-39.9	10.5	-43.5	12.4	-51.0	14.3	-59.2	16.5	-67.9	18.7	-77.3	23.7	-97.8	29.3	-120.7
	2	20	8.3	-32.6	9.1	-35.7	9.9	-38.8	11.6	-45.6	13.4	-52.9	15.4	-60.7	17.6	-69.0	22.2	-87.4	27.4	-107.9
	2	50	7.6	-27.5	8.3	-30.1	9.0	-32.7	10.6	-38.4	12.3	-44.5	14.1	-51.1	16.0	-58.2	20.3	-73.6	25.0	-90.9
	2	100	7.0	-23.6	7.7	-25.8	8.3	-28.1	9.8	-33.0	11.4	-38.2	13.0	-43.9	14.8	-50.0	18.8	-63.2	23.2	-78.1
	3	10	8.9	-55.0	9.7	-21.8	10.5	-65.4	12.4	-76.8	14.3	-89.0	16.5	-102.2	18.7	-116.3	23.7	-147.2	29.3	-181.7
	3	20	8.3	-45.5	9.1	-21.2	9.9	-54.2	11.6	-63.6	13.4	-73.8	15.4	-84.7	17.6	-96.3	22.2	-121.9	27.4	-150.5
	3	50	7.6	-33.1	8.3	-20.4	9.0	-39.3	10.6	-46.2	12.3	-53.5	14.1	-61.5	16.0	-69.0	20.3	-88.5	25.0	-109.3
	3	100	7.0	-23.6	7.7	-19.8	8.3	-28.1	9.8	-33.0	11.4	-38.2	13.0	-43.9	14.8	-50.0	18.8	-63.2	23.2	-78.1
Roof > 7 to 27 degrees	1	10	12.5	-19.9	13.7	-37.9	14.9	-23.7	17.5	-27.8	20.3	-32.3	23.3	-37.0	28.5	-42.1	33.6	-53.3	41.5	-65.9
	1	20	11.4	-19.4	12.5	-34.9	13.6	-23.0	16.0	-27.0	18.5	-31.4	21.3	-36.0	24.2	-41.0	30.6	-51.9	37.8	-64.0
	1	50	10.0	-18.6	10.9	-30.9	11.9	-22.2	13.9	-26.0	16.1	-30.2	18.5	-34.6	21.1	-39.4	26.7	-49.9	32.9	-61.6
	1	100	8.9	-18.1	9.7	-27.8	10.5	-21.5	12.4	-25.2	14.3	-29.3	16.5	-33.6	18.7	-38.2	23.7	-48.4	29.3	-59.8
	2	10	12.5	-34.7	13.7	-56.0	14.9	-41.3	17.5	-48.4	20.3	-56.2	23.3	-64.5	26.5	-73.4	33.6	-92.9	41.5	-114.6
	2	20	11.4	-31.9	12.5	-52.4	13.6	-38.0	16.0	-44.6	18.5	-51.7	21.3	-59.3	24.2	-67.5	30.6	-85.4	37.8	-105.5
	2	50	10.0	-28.2	10.9	-47.6	11.9	-33.6	13.9	-39.4	16.1	-45.7	18.5	-52.5	21.1	-59.7	26.7	-75.6	32.9	-93.3
	2	100	8.9	-25.5	9.7	-44.0	10.5	-30.3	12.4	-35.6	14.3	-41.2	16.5	-47.3	18.7	-53.9	23.7	-68.2	29.3	-84.2
	3	10	12.5	-51.3	13.7	-23.8	14.9	-61.0	17.5	-71.6	20.3	-83.1	23.3	-95.4	26.5	-108.5	33.6	-137.3	41.5	-169.5
	3	20	11.4	-47.9	12.5	-22.6	13.6	-57.1	16.0	-67.0	18.5	-77.7	21.3	-89.2	24.2	-101.4	30.6	-128.4	37.8	-158.5
	3	50	10.0	-43.5	10.9	-21.0	11.9	-51.8	13.9	-60.8	16.1	-70.5	18.5	-81.0	21.1	-92.1	26.7	-116.6	32.9	-143.9
	3	100	8.9	-40.2	9.7	-19.8	10.5	-47.9	12.4	-56.2	14.3	-65.1	16.5	-74.8	18.7	-85.1	23.7	-107.7	29.3	-132.9
Roof > 27 to 45 degrees	1	10	19.9	-21.8	21.8	-27.6	23.7	-25.9	27.8	-30.4	32.3	-35.3	37.0	-40.5	42.1	-46.1	53.3	-58.3	65.9	-72.0
	1	20	19.4	-20.7	21.2	-26.6	23.0	-24.6	27.0	-28.9	31.4	-33.5	36.0	-38.4	41.0	-43.7	51.9	-55.3	64.0	-68.3
	1	50	18.6	-19.2	20.4	-25.0	22.2	-22.8	26.0	-26.8	30.2	-31.1	34.6	-35.7	39.4	-40.6	49.9	-51.4	61.6	-63.4
	1	100	18.1	-18.1	19.8	-23.8	21.5	-21.5	25.2	-25.2	29.3	-29.3	33.6	-33.6	38.2	-38.2	48.4	-48.4	59.8	-59.8
	2	10	19.9	-25.5	21.8	-27.8	23.7	-30.3	27.8	-35.6	32.3	-41.2	37.0	-47.3	42.1	-53.9	53.3	-68.2	65.9	-84.2
	2	20	19.4	-24.3	21.2	-26.6	23.0	-29.0	27.0	-34.0	31.4	-39.4	36.0	-45.3	41.0	-51.5	51.9	-65.2	64.0	-80.5
	2	50	18.6	-22.9	20.4	-25.0	22.2	-27.2	26.0	-32.0	30.2	-37.1	34.6	-42.5	39.4	-48.4	49.9	-61.3	61.6	-75.6
	2	100	18.1	-21.8	19.8	-23.8	21.5	-25.9	25.2	-30.4	29.3	-35.3	33.6	-40.5	38.2	-46.1	48.4	-58.3	59.8	-72.0
	3	10	19.9	-25.5	21.8	-27.8	23.7	-30.3	27.8	-35.6	32.3	-41.2	37.0	-47.3	42.1	-53.9	53.3	-68.2	65.9	-84.2
	3	20	19.4	-24.3	21.2	-26.6	23.0	-29.0	27.0	-34.0	31.4	-39.4	36.0	-45.3	41.0	-51.5	51.9	-65.2	64.0	-80.5
	3	50	18.6	-22.9	20.4	-25.0	22.2	-27.2	26.0	-32.0	30.2	-37.1	34.6	-42.5	39.4	-48.4	49.9	-61.3	61.6	-75.6
	3	100	18.1	-21.8	19.8	-23.6	21.5	-25.9	25.2	-30.4	29.3	-35.3	33.6	-40.5	38.2	-46.1	48.4	-58.3	59.8	-72.0
Wall	4	10	21.8	-23.6	23.8	-25.8	25.9	-28.1	30.4	-33.0	35.3	-38.2	40.5	-43.9	46.1	-50.0	58.3	-63.2	72.0	-78.1
	4	20	20.8	-22.6	22.7	-24.7	24.7	-26.9	29.0	-31.6	33.7	-36.7	38.7	-42.1	44.0	-47.9	55.7	-60.6	68.7	-74.8
	4	50	19.5	-21.3	21.3	-23.3	23.2	-25.4	27.2	-29.8	31.6	-34.6	36.2	-39.7	41.2	-45.1	52.2	-57.1	64.4	-70.6
	4	100	18.5	-20.4	20.2	-22.2	22.0	-24.2	25.9	-28.4	30.0	-33.0	34.4	-37.8	39.2	-43.1	49.6	-54.5	61.2	-67.3
	4	500	16.2	-18.1	17.7	-19.8	19.3	-21.5	22.7	-25.2	26.3	-29.3	30.2	-33.6	34.3	-38.2	43.5	-48.4	53.7	-59.8
	5	10	21.8	-29.1	23.8	-31.9	25.9	-34.7	30.4	-40.7	35.3	-47.2	40.5	-54.2	46.1	-61.7	58.3	-78.0	72.0	-96.3
	5	20	20.8	-27.2	22.7	-29.7	24.7	-32.4	29.0	-38.0	33.7	-44.0	38.7	-50.5	44.0	-57.5	55.7	-72.8	68.7	-89.9
	5	50	19.5	-24.6	21.3	-26.9	23.2	-29.3	27.2	-34.3	31.6	-39.8	36.2	-45.7	41.2	-52.0	52.2	-65.8	64.4	-81.3
	5	100	18.5	-22.6	20.2	-24.7	22.0	-26.9	25.9	-31.6	30.0	-36.7	34.4	-42.1	39.2	-47.9	49.6	-60.6	61.2	-74.8
	5	500	16.2	-18.1	17.7	-19.8	19.3	-21.5	22.7	-25.2	26.3	-29.3	30.2	-33.6	34.3	-38.2	43.5	-48.4	53.7	-59.8

For SI: 1 foot = 304.8 mm, 1 square foot = 0.0929 m<sup>2</sup>, 1 mile per hour = 0.447 m/s, 1 pound per square foot = 0.0479 kPa.

Notes:

- a. The effective wind area shall be equal to the span length multiplied by an effective width. This width shall be permitted to be not less than one-third the span length. For cladding fasteners, the effective wind area shall not be greater than the area that is tributary to an individual fastener.
- b. For effective areas between those given above, the load may be interpolated; otherwise, use the load associated with the lower effective area.
- c. Table values shall be adjusted for height and exposure by multiplying by the adjustment coefficient in Table R301.2(3).
- d. See Figure R301.2(7) for location of zones.
- e. Plus and minus signs signify pressures acting toward and away from the building surfaces.
- f. Positive design wind pressures shall not be less than +16 psf and negative design wind pressures shall not be less than -16 psf.

**TABLE R301.2(3)**  
**HEIGHT AND EXPOSURE ADJUSTMENT COEFFICIENTS FOR TABLE R301.2(2)**

MEAN ROOF HEIGHT	EXPOSURE		
	B	C	D
15	1.00	1.21	1.47
20	1.00	1.29	1.55
25	1.00	1.35	1.61
30	1.00	1.40	1.66
35	1.05	1.45	1.70
40	1.09	1.49	1.74
45	1.12	1.53	1.78
50	1.16	1.56	1.81
55	1.19	1.59	1.84
60	1.22	1.62	1.87

**TABLE R301.2(4)**  
**GARAGE DOOR LOADS FOR A BUILDING WITH A MEAN ROOF HEIGHT OF 30 FEET LOCATED IN EXPOSURE B**

		$V_{asd}$ AS DETERMINED IN ACCORDANCE WITH SECTION R301.2.1.3 (MPH – 3 SECOND GUST)													
Roof Angle > 10 degrees Effective Area:		90		100		110		120		130		140		150	
Width (ft)	Height (ft)														
9	7	12.8	-14.5	15.8	-17.9	19.1	-21.6	22.8	-25.8	26.7	-30.2	31.0	-35.1	35.6	-40.2
16	7	12.3	-13.7	15.2	-16.9	18.3	-20.4	21.8	-24.3	25.6	-28.5	29.7	-33.1	34.1	-38.0

For SI: 1 foot = 304.8 mm, 1 square foot = 0.0929 m<sup>2</sup>, 1 mile per hour = 1.609 km/h

1. For effective areas or wind speeds between those given above the load may be interpolated, otherwise use the load associated with the lower effective area.
2. Table values shall be adjusted for height and exposure by multiplying by the adjustment coefficient in Table R301.2(3).
3. Plus and minus signs signify pressures acting toward and away from the building surfaces.
4. Negative pressures assume door has 2 feet of width in building's end zone.

**R301.2.1.1 Design criteria.** In regions where the ultimate design wind speeds,  $V_{ult}$ , from Figure R301.2(4) equal or exceed 115 miles per hour (45 m/s) the design of buildings shall be in accordance with one of the following methods. The elements of design not addressed by those documents in Items 1 through 8 shall be in accordance with this code.

1. American Forest and Paper Association (AF&PA) *Wood Frame Construction Manual for One- and Two-Family Dwellings* (WFCM).
2. International Code Council (ICC) *Standard for Residential Construction in High Wind Regions* (ICC-600).
3. *Minimum Design Loads for Buildings and Other Structures* (ASCE-7).
4. American Iron and Steel Institute (AISI), *Standard for Cold-Formed Steel Framing—Prescriptive Method For One- and Two-Family Dwellings* (AISI S230).
5. Concrete construction shall be designed in accordance with the provisions of this code.
6. The MAF Guide to Concrete Masonry Residential Construction in High Wind Areas shall be permitted for applicable concrete masonry buildings where  $V_{asd}$  determined in accordance with Section

R301.2.1.3 does not exceed 130 mph (58 m/s) in Exposure B and 110 mph (49 m/s) in Exposure C in accordance with Figure R301.2(4).

7. The applicable AF&PA *WFCM Guide to Wood Construction in High Wind Areas* shall be permitted for applicable wood-frame buildings in regions where  $V_{asd}$  determined in accordance with Section R301.2.1.3 does not exceed 130 mph (58 m/s) in Exposure B.
8. Structural insulated panel (SIP) walls shall be designed in accordance with the provisions of this code.

The wind speeds in Figure R301.2(4) shall be converted to nominal wind speeds,  $V_{asd}$ , in accordance with Section R301.2.1.3 when the provisions of the standards referenced in Exceptions 1 through 8 are used unless the wind provisions in the standards are based on Ultimate Wind Speeds as specified in Figure R301.2(4) or Chapter 26 of ASCE 7.

**R301.2.1.1.1 Design.** The following design guide shall be accepted as conforming to accepted engineering practices: AAF *Guide to Aluminum Construction in High-Wind Areas*. Vinyl and acrylic panels shall be removable. Removable panels shall be identified as removable by a decal. The identification decal shall essentially state: "Removable panel SHALL be

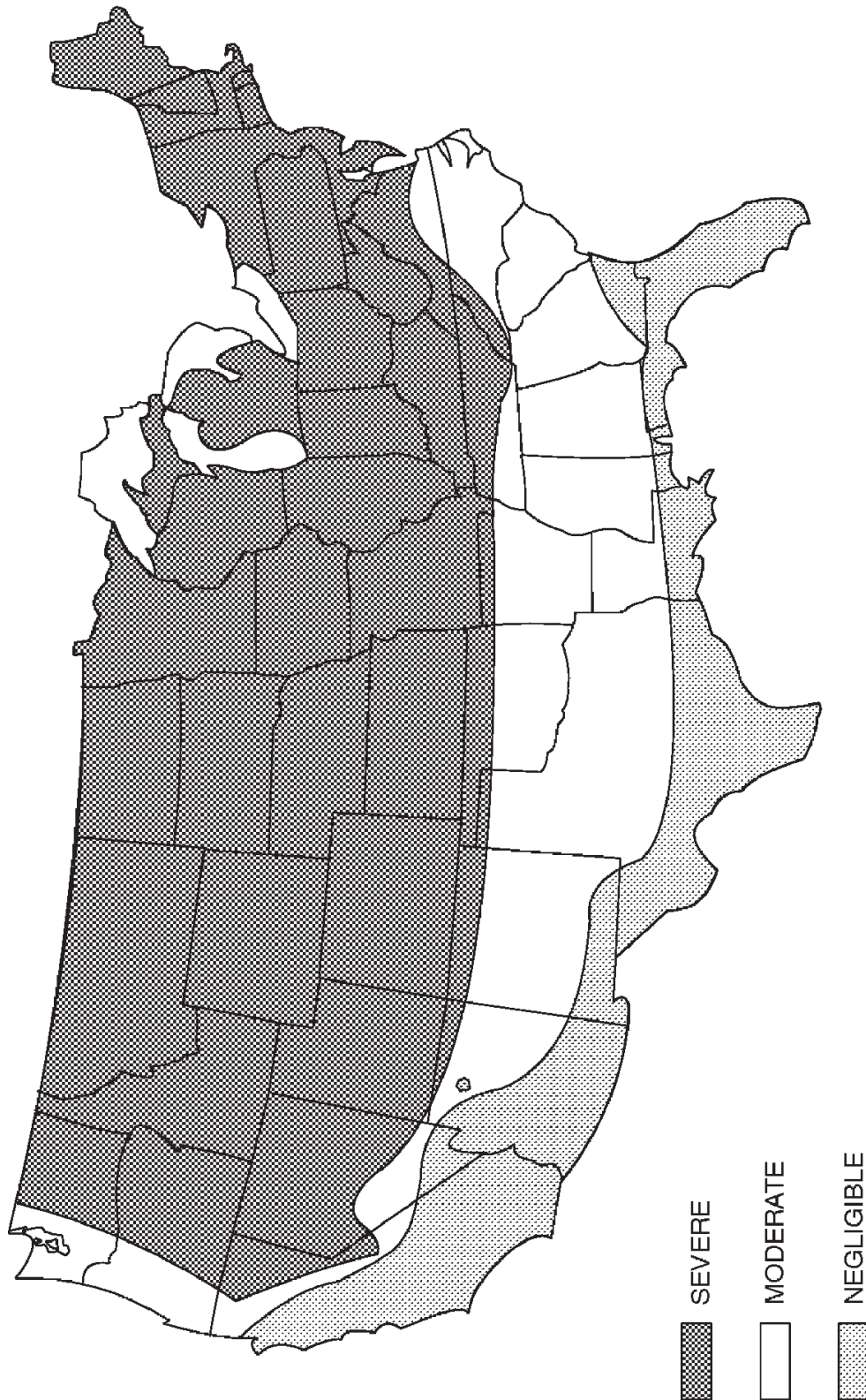

a. Alaska and Hawaii are classified as severe and negligible, respectively.  
 b. Lines defining areas are approximate only. Local conditions may be more or less severe than indicated by region classification. A severe classification is where weather conditions result in significant snowfall combined with extended periods during which there is little or no natural thawing causing deicing salts to be used extensively.

**FIGURE R301.2(3)  
 WEATHERING PROBABILITY MAP FOR CONCRETE**

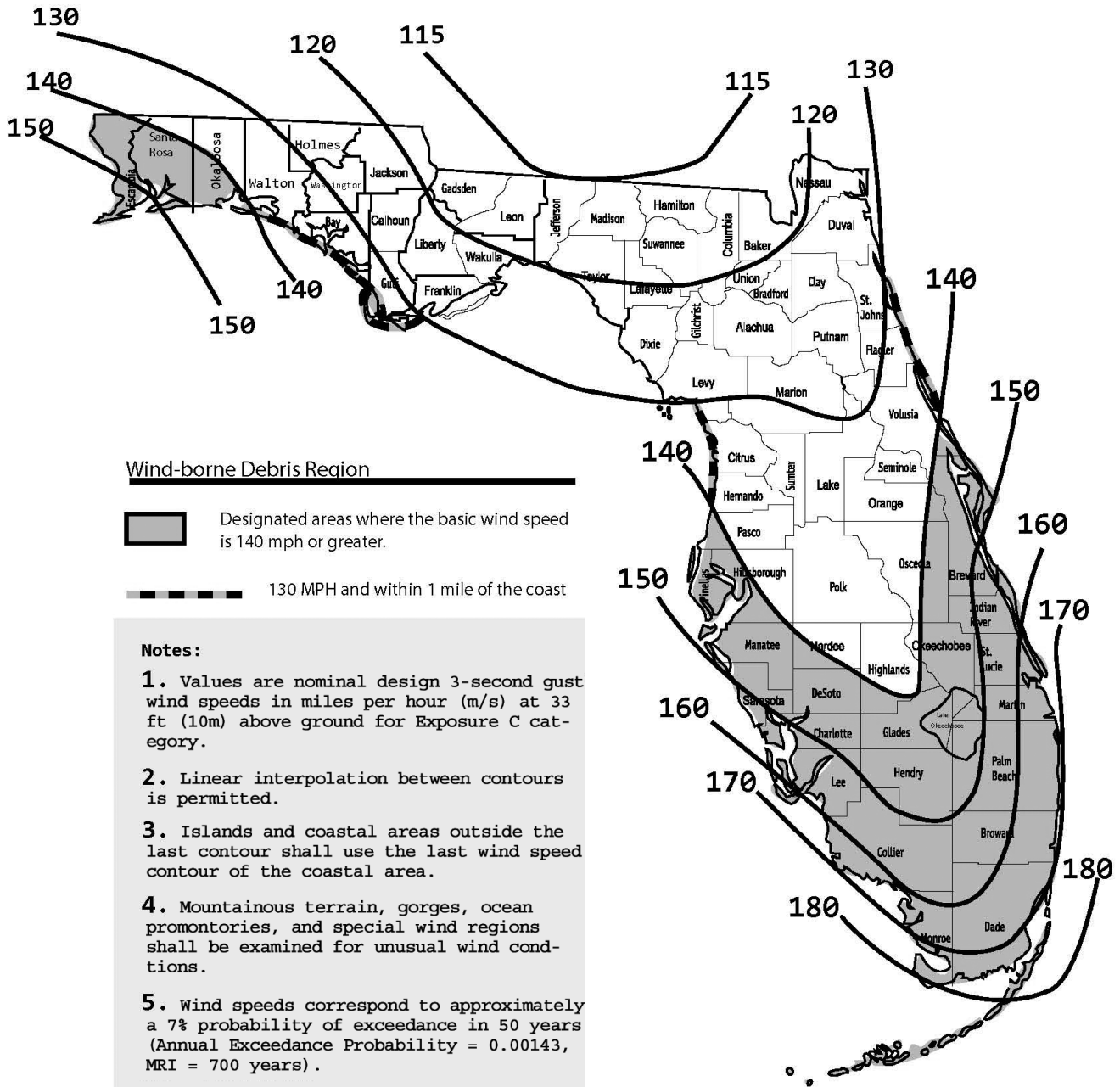
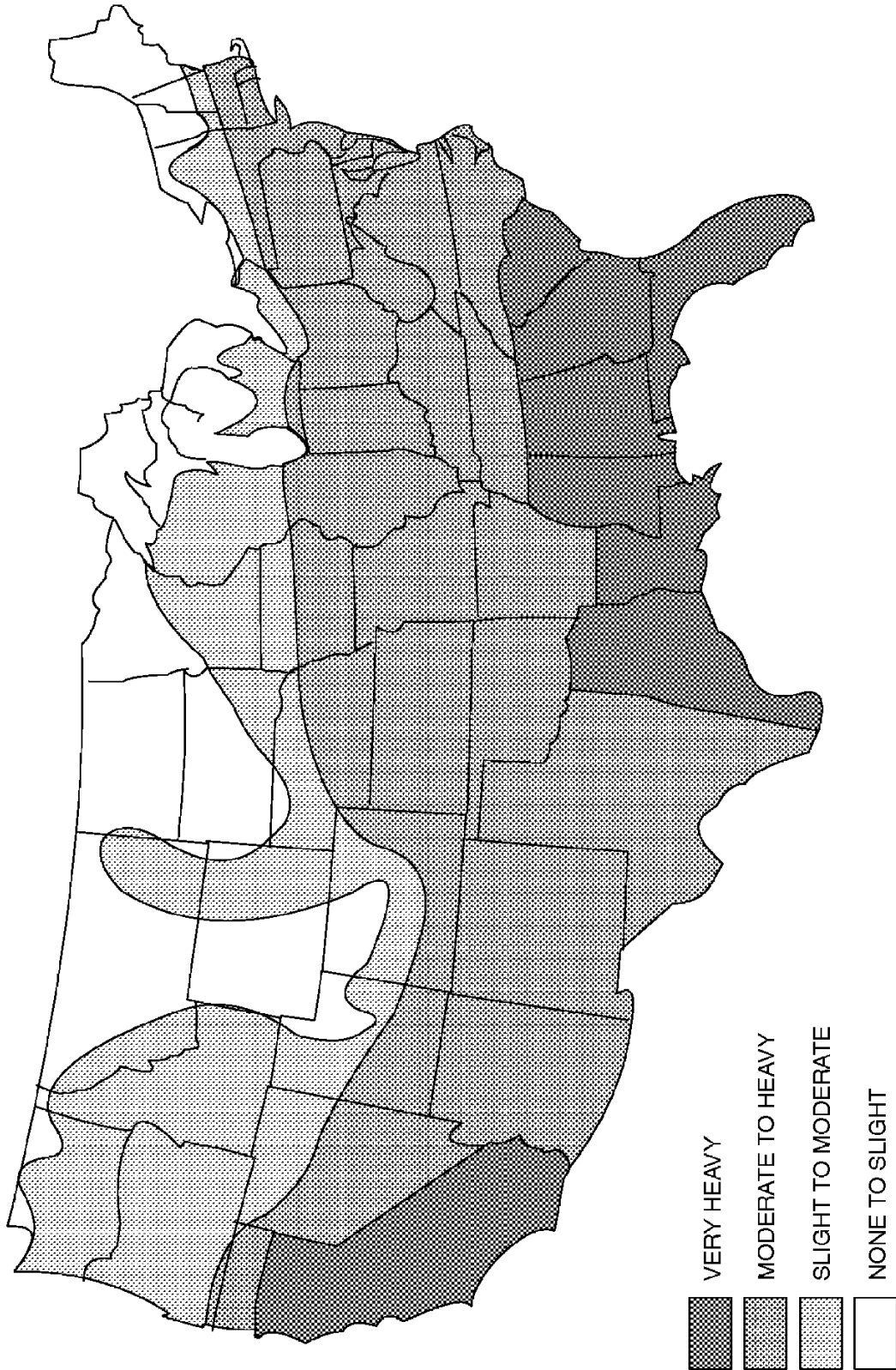

FIGURE R301.2(4)  
ULTIMATE DESIGN WIND SPEEDS,  $V_{ult}$

For SI: 1 foot = 304.8 mm, 1 mile per hour = 0.447 m/s.



NOTE: Lines defining areas are approximate only. Local conditions may be more or less severe than indicated by the region classification.

FIGURE R301.2(6)  
TERMITE INFESTATION PROBABILITY MAP

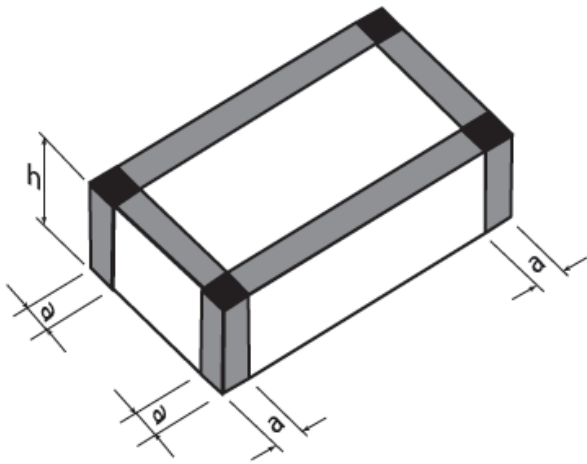

Flat Roof

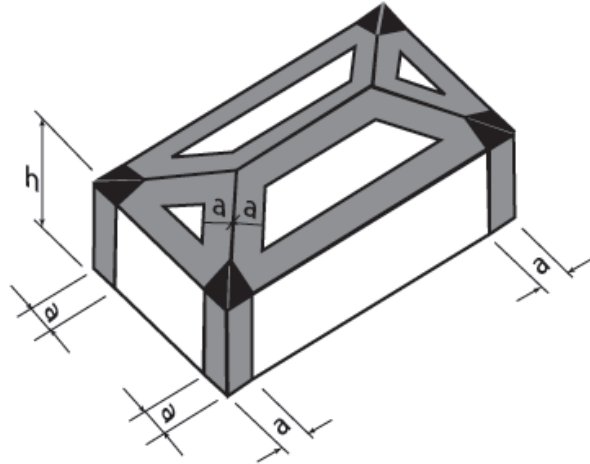

Hip Roof ( $7^\circ < \theta \leq 27^\circ$ )

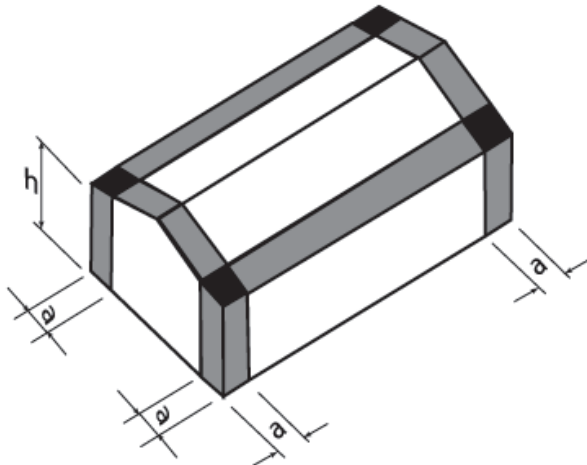

Gable Roof ( $\theta \leq 7^\circ$ )

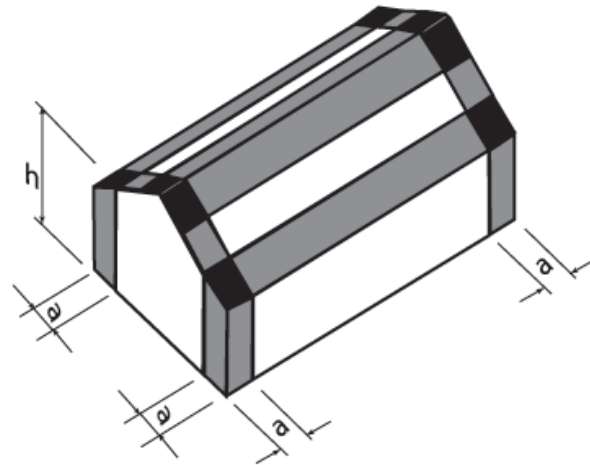

Gable Roof ( $7^\circ < \theta \leq 45^\circ$ )

 Interior Zones  
Roofs - Zone 1 / Walls - Zone 4

 End Zones  
Roofs - Zone 2 / Walls - Zone 5

 Corner Zones  
Roofs - Zone 3

For SI: 1 foot = 304.8 mm, 1 degree = 0.0175 rad.  
**Note:** a = 4 feet in all cases.

**FIGURE R301.2(7)**  
**COMPONENT AND CLADDING PRESSURE ZONES**



removed when wind speeds exceed 75 mph (34 m/s).” Decals shall be placed such that the decal is visible when the panel is installed.

**R301.2.1.1.2 Sunrooms.** Sunrooms shall comply with AAMA/NPEA/NSA 2100 with the structural requirements and testing provisions of Chapter 5.

AAMA 2100, Section 5.2.1 Wind Loads: Modify Section 5.2.1 as follows:

5.2.1 Wind Loads: Basic wind speed ( $V_{asd}$ ) in miles per hour (mph) shall be determined in accordance with Section R301.2.1. Sunrooms including exposed structures, components, cladding, and roof covering shall be designed to resist the wind loads as established in Section R301.2.1.

For the purpose of applying the criteria of the AAMA Standard for sunrooms based on the intended use, sunrooms shall be categorized in one of the following categories by the permit applicant, design professional or the property owner where the sunroom is being constructed.

**Category I:** A roof or a covering of an outdoor space. The openings shall be permitted to be enclosed with insect screening or 0.5 mm (20 mil) maximum thickness plastic film. The space is defined as nonhabitable and unconditioned.

**Category II:** A roof or a covering of an outdoor space with enclosed walls. The openings are permitted to be enclosed with translucent or transparent plastic or glass. The space is defined as nonhabitable and unconditioned.

**Category III:** A roof or a covering of an outdoor space with enclosed walls. The openings are permitted to be enclosed with translucent or transparent plastic or glass. The sunroom complies with additional requirements for forced-entry resistance, air-leakage resistance and water-penetration resistance. The space is defined as nonhabitable and unconditioned.

**Category IV:** A roof or a covering of an outdoor space with enclosed walls. The sunroom is designed to be heated and/or cooled by a separate temperature control or system and is thermally isolated from the primary structure. The sunroom complies with additional requirements for forced-entry resistance, water penetration resistance, air-leakage resistance, and thermal performance. The space is defined as habitable and conditioned.

**Category V:** A roof or a covering of an outdoor space with enclosed walls. The sunroom is designed to be heated and/or cooled and is open to the main structure. The sunroom complies with additional requirements for forced-entry resistance, water-penetration resistance, air-leakage resistance, and thermal performance. The space is defined as habitable and conditioned.

**R301.2.1.1.3 Wind loads on rooftop structures and equipment.** The lateral force on rooftop structures and equipment with  $A_r$  less than (0.1 Bh) located on buildings of all heights shall be determined from Eq. 29.5-1 of ASCE 7 in which the value of  $GC_r$  is 3.1.  $GC_r$  shall be permitted to be reduced linearly from 3.1 to 1.1 as the value of  $A_r$  is increased from (0.1 Bh) to (Bh). The value of G from Section 26.9 of ASCE 7 shall not be used. Additionally, a simultaneous uplift force shall be applied, given by Equation 29.5-1 of ASCE 7 in which  $GC_r = 1.5$  and  $A_r$  is replaced by the horizontal projected area,  $A_r$ , of the rooftop structure or equipment. For the uplift force,  $GC_r$  shall be permitted to be reduced linearly from 1.5 to 1.0 as the value of  $A_r$  is increased from (0.1BL) to (BL).

**R301.2.1.2 Protection of openings.** Windows in buildings located in windborne debris regions shall have glazed openings protected from windborne debris. Glazed opening protection for windborne debris shall meet the requirements of the Large Missile Test of ASTM E 1996, ASTM E 1886, SSTD 12 or TAS 201, 202 and 203 or AAMA 506 referenced therein. Garage door glazed opening protection for windborne debris shall meet the requirements of an *approved* impact resistant standard or ANSI/DASMA 115.

1. Opening in sunrooms, balconies or enclosed porches constructed under existing roofs or decks are not required to be protected provided the spaces are separated from the building interior by a wall and all openings in the separating wall are protected in accordance with this section. Such space shall be permitted to be designed as either partially enclosed or enclosed structures.
2. Storage sheds that are not designed for human habitation and that have a floor area of 720 square feet (67 m<sup>2</sup>) or less are not required to comply with the mandatory wind-borne debris impact standard of this code.
3. Ventilation openings in an exterior wall into an attic space in buildings located in windborne debris regions shall have opening protection from windborne debris. Such opening protection into an attic space shall meet the requirements AMCA 540 or shall be protected by an impact resistant cover complying with an approved impact-resistance standard or the large missile test of ASTM E 1996.

Impact resistant coverings shall be tested at 1.5 times the design pressure (positive or negative) expressed in pounds per square feet as determined by the *Florida Building Code, Residential* Section R301, for which the specimen is to be tested.

**Exception:** Wood structural panels with a minimum thickness of  $7/16$  inch (11 mm) and a maximum span of 8 feet (2438 mm) shall be permitted for opening protection in one- and two-story buildings. Panels shall be precut and attached to the framing surrounding the opening containing the product with the glazed opening. Panels shall be predrilled as required for the

anchorage method and shall be secured with the attachment hardware provided. Attachments shall be designed to resist the component and cladding loads determined in accordance with either Table R301.2(2) or ASCE 7, with the permanent corrosion-resistant attachment hardware provided and anchors permanently installed on the building. Attachment in accordance with Table R301.2.1.2 is permitted for buildings with a mean roof height of 33 feet (10 058 mm) or less where  $V_{asd}$  determined in accordance with Section R301.2.1.3 does not exceed 130 miles per hour (58 m/s).

**TABLE R301.2.1.2**  
**WINDBORNE DEBRIS PROTECTION FASTENING SCHEDULE**  
**FOR WOOD STRUCTURAL PANELS<sup>a, b, c, d</sup>**

FASTENER TYPE	FASTENER SPACING (inches) <sup>a, b</sup>		
	Panel span ≤ 4 feet	4 feet < panel span ≤ 6 feet	6 feet < panel span ≤ 8 feet
No. 8 wood screw based anchor with 2-inch embedment length	16	10	8
No. 10 wood screw based anchor with 2-inch embedment length	16	12	9
1/4-inch lag screw based anchor with 2-inch embedment length	16	16	16

For SI: 1 inch = 25.4 mm, 1 foot = 304.8 mm, 1 pound = 4.448 N, 1 mile per hour = 0.447 m/s.

- a. This table is based on  $V_{asd}$ , as determined in accordance with Section R301.2.1.3, of 130 mph and a 33-foot mean roof height.
- b. Fasteners shall be installed at opposing ends of the wood structural panel. Fasteners shall be located a minimum of 1 inch from the edge of the panel.
- c. Anchors shall penetrate through the exterior wall covering with an embedment length of 2 inches minimum into the building frame. Fasteners shall be located a minimum of 2 1/2 inches from the edge of concrete block or concrete.
- d. Where panels are attached to masonry or masonry/stucco, they shall be attached using vibration-resistant anchors having a minimum ultimate withdrawal capacity of 1500 pounds.

**R301.2.1.2.1 Modifications to ASTM E 1996.** Section 6.2.2 of ASTM E 1996 shall be modified as follows:

6.2.2 Unless otherwise specified, select the wind zone based on the basic wind speed as follows:

6.2.2.1 *Wind Zone 1* - 130 mph ≤ basic wind speed < 140 mph, and Hawaii.

6.2.2.2 *Wind Zone 2* – 140 mph ≤ basic wind speed < 150 mph at greater than 1.6 km (one mile) from the coastline. The coastline shall be measured from the mean high water mark.

6.2.2.3 *Wind Zone 3* – 150 mph (58 m/s) ≤ basic wind speed ≤ 160 mph (63 m/s), or 140 mph (54 m/s) ≤ basic wind speed ≤ 160 mph (63 m/s) and within 1.6 km (one mile) of the coastline. The coastline shall be measured from the mean high water mark.

6.2.2.4 *Wind Zone 4* – basic wind speed > 160 mph (63 m/s).

**R301.2.1.2.1.1 Modifications to ASTM E 1886 and ASTM E 1996.** Table 1 of ASTM E 1886 and ASTM E 1996 shall be amended to add a column and notes to read as follows:

**Air Pressure Cycles**

- 0.2 to 0.5  $P_{pos}^1$
- 0.0 to 0.6  $P_{pos}^1$
- 0.5 to 0.8  $P_{pos}^1$
- 0.3 to 1.0  $P_{pos}^1$
- 0.3 to 1.0  $P_{neg}^2$
- 0.5 to 0.8  $P_{neg}^2$
- 0.0 to 0.6  $P_{neg}^2$
- 0.2 to 0.5  $P_{neg}^2$

Notes:

- 1.  $P_{pos}$  = 0.6 × positive ultimate design load in accordance with ASCE 7.
- 2.  $P_{neg}$  = 0.6 × negative ultimate design load in accordance with ASCE 7.

**R301.2.1.3 Wind speed conversion.** When required ultimate design wind speeds,  $V_{ult}$ , of Figure R301.2(4) shall be converted to nominal design wind speeds,  $V_{asd}$ , using Table R301.2.1.3.

**R301.2.1.4 Exposure category.** For each wind direction considered, an exposure category that adequately reflects the characteristics of ground surface irregularities shall be determined for the site at which the building or structure is to be constructed. For a site located in the transition zone between categories, the category resulting in the largest wind forces shall apply. Account shall be taken of variations in ground surface roughness that arise from natural topography and vegetation as well as from constructed features. For any given wind direction, the exposure in which a specific building or other struc-

**TABLE R301.2.1.3**  
**WIND SPEEDS CONVERSIONS<sup>a, b, c</sup>**

$V_{ult}$	100	110	120	130	140	150	160	170	180	190	200
$V_{asd}$	78	85	93	101	108	116	124	132	139	147	155

For SI: 1 mile per hour = 0.447 m/s.

- a. Linear interpolation is permitted.
- b.  $V_{asd}$  = nominal design wind speed.
- c.  $V_{ult}$  = ultimate design wind speed determined from Figure R301.2(4).

ture is sited shall be assessed as being one of the following categories:

**Exception:** An intermediate exposure between the exposure categories defined is permitted in a transition zone provided that it is determined by a rational analysis method.

**R301.2.1.4.1 Wind directions and sectors.** For each selected wind direction at which the wind loads are to be evaluated, the exposure of the building or structure shall be determined for the two upwind sectors extending 45 degrees (0.79 rad) either side of the selected wind direction. The exposures in these two sectors shall be determined in accordance with Sections R301.2.1.4.2 and R301.2.1.4.3 and the exposure resulting in the highest wind loads shall be used to represent winds from that direction.

**R301.2.1.4.2 Surface roughness categories.** A ground surface roughness within each 45-degree (0.79 rad) sector shall be determined for a distance upwind of the site as defined in Section R301.2.1.4.3 from the categories defined below, for the purpose of assigning an exposure category as defined in Section R301.2.1.4.3.

**Surface Roughness B.** Urban and suburban areas, wooded areas or other terrain with numerous closely spaced obstructions having the size of single-family dwellings or larger.

**Surface Roughness C.** Open terrain with scattered obstructions having heights generally less than 30 feet (9144 mm). This category includes flat open country and grasslands. This surface roughness shall also apply to any building located within surface roughness B-type terrain where the building is within 100 feet horizontally in any direction of open areas of surface roughness C- or D-type terrain that extends more than 600 feet (182.9 m) and width greater than 150 ft. in the upwind direction. Short-term (less than two year) changes in the pre-existing terrain exposure, for the purposes of development, shall not be considered surface roughness C. Where development buildout will occur within three years and the resultant condition will meet the definition of surface roughness B, surface roughness B shall be regulating for the purpose of permitting. This category includes flat open country and grasslands and shall extend downwind for a distance of 1500 feet.

**Surface Roughness D.** Flat, unobstructed areas and water surfaces. This category includes smooth mud flats, salt flats and unbroken ice.

**R301.2.1.4.3 Exposure categories.** An exposure category shall be determined in accordance with the following:

**Exposure B.** For buildings with a mean roof height of less than or equal to 30 feet, Exposure B shall apply where the ground surface roughness, as defined by Surface Roughness B, prevails in the

upwind direction for a distance of at least 1,500 feet (457 m). For buildings with a mean roof height greater than 30 feet, Exposure B shall apply where Surface Roughness B prevails in the upwind direction for a distance of at least 2,600 feet (792 m) or 20 times the height of the building, whichever is greater.

**Exposure C.** Exposure C shall apply for all cases where Exposures B or D do not apply.

**Exposure D.** Exposure D shall apply where the ground surface roughness, as defined by Surface Roughness D, prevails in the upwind direction for a distance of at least 5,000 feet (1524 m) or 20 times the height of the building, whichever is greater. Exposure D shall also apply where the ground surface roughness immediately upwind of the site is B or C, and the site is within a distance of 600 feet (183 m) or 20 times the building height, whichever is greater, from an exposure D condition as defined in the previous sentence.

**R301.2.1.5 Topographic wind effects.** Reserved.

**R301.2.1.5.1 Simplified topographic wind speed-up method.** Reserved.

**Figure R301.2.1.5.1(1) Topographic Features For Wind Speed-Up Effect.** Reserved.

**Figure R301.2.1.5.1(2) Illustration Of Where On A Topographic Feature, Wind Speed Increase Is Applied.** Reserved.

**Figure R301.2.1.5.1(3) Illustration Of Upwind Obstruction.** Reserved.

**Table R301.2.1.5.1 Basic Wind Modification For Topographic Wind Effect.** Reserved.

**R301.2.1.6 Basic wind speed.** The ultimate design wind speed,  $V_{ult}$ , in miles per hour, for the development of windloads, shall be determined from Figure R301.2(4). The exact location of wind speed lines shall be established by local ordinance using recognized physical landmarks such as major roads, canals, rivers and lake shores whenever possible.

**R301.2.1.7 Testing to allowable or nominal loads.** Where testing for wind load resistance is based on allowable or nominal wind loads, the design wind loads determined in accordance with ASCE 7 or Section 1609 of the *Florida Building Code, Building* are permitted to be multiplied by 0.6 for the purposes of the wind load resistance testing.

**R301.2.2 Seismic provisions.** Reserved.

**Figure R301.2(2) Seismic design categories.** Reserved.

**Figure R301.2(5) Ground snow loads for the United States.** Reserved.

**R301.2.2.1 Determination of seismic design category.** Reserved.

**R301.2.2.1.1 Alternate determination of seismic design category.** Reserved.

**Table 301.2.2.1.1 Seismic Design Category Determination.** Reserved.

**R301.2.2.1.2 Alternative determination of Seismic Design Category E.** Reserved.

**R301.2.2.2 Seismic Design Category C.** Reserved.

**R301.2.2.2.1 Weights of materials.** Reserved.

**Table R301.2.2.2.1 Wall Bracing Adjustment Factors By Roof Covering Dead Load.** Reserved.

**R301.2.2.2.2 Stone and masonry veneer.** Reserved.

**R301.2.2.2.3 Masonry construction.** Reserved.

**R301.2.2.2.4 Concrete construction.** Reserved.

**R301.2.2.2.5 Irregular buildings.** Reserved.

**R301.2.2.3 Seismic Design Categories D<sub>0</sub>, D<sub>1</sub> and D<sub>2</sub>.** Reserved.

**R301.2.2.3.1 Height limitations.** Reserved.

**R301.2.2.3.2 Stone and masonry veneer.** Reserved.

**R301.2.2.3.3 Masonry construction.** Reserved.

**R301.2.2.3.4 Concrete construction.** Reserved.

**R301.2.2.3.5 Cold-formed steel framing in Seismic Design Categories D<sub>0</sub>, D<sub>1</sub> and D<sub>2</sub>.** Reserved.

**R301.2.2.3.6 Masonry chimneys.** Reserved.

**R301.2.2.3.7 Anchorage of water heaters.** Reserved.

**R301.2.2.4 Seismic Design Category E.** Reserved.

**R301.2.3 Snow loads.** Reserved.

**R301.2.4 Floodplain construction.** Buildings and structures constructed in whole or in part in flood hazard areas (including A or V Zones) as established in Table R301.2(1) shall be designed and constructed in accordance with Section R322.

**Exception:** Buildings and structures located in whole or in part in identified floodways shall be designed and constructed in accordance with ASCE 24.

**R301.2.4.1 Alternative provisions.** As an alternative to the requirements in Section R322.2 for buildings and structures located in whole or in part in flood hazard areas (A Zones) or the requirements of Section 322.3 in coastal high hazard areas (V Zones), ASCE 24 is permitted subject to the limitations of this code and the limitations therein.

**R301.2.5 Structures seaward of a coastal construction line.** Structures located seaward of the coastal construction line shall be designed to resist the predicted forces of a 100-year storm event in accordance with Section 3109 of the *Florida Building Code, Building*.

**R301.3 Story height.** Buildings constructed in accordance with these provisions shall be limited to *story heights* of not more than the following:

1. For conventional light-frame wood construction, the laterally unsupported bearing wall stud height permitted plus a height of floor framing not to exceed sixteen inches. For purposes of determining uplift, gravity loads, and lateral bracing requirements, an attic shall be considered an additional story when the roof slope is 6 in 12 or greater. (See Figure R301.3.)
2. For steel wall framing, a stud height of 10 feet (3048 mm), plus a height of floor framing not to exceed 16 inches (406 mm).
3. For masonry walls, a maximum bearing wall clear height of 12 feet (3658 mm) plus a height of floor framing not to exceed 16 inches (406 mm).

**Exception:** An additional 8 feet (2438 mm) is permitted for gable end walls.

4. For insulating concrete form walls, the maximum bearing wall height per *story* as permitted by Section R611 tables plus a height of floor framing not to exceed 16 inches (406 mm).
5. For structural insulated panel (SIP) walls, the maximum bearing wall height per *story* as permitted by Section 614 tables shall not exceed 10 feet (3048 mm) plus a height of floor framing not to exceed 16 inches (406 mm).

Individual walls or walls studs shall be permitted to exceed these limits as permitted by Chapter 6 provided *story heights* are not exceeded. Floor framing height shall be permitted to exceed these limits provided the *story height* does not exceed 11 feet 7 inches (3531 mm). An engineered design shall be provided for the wall or wall framing members when they exceed the limits of Chapter 6. Where the *story height* limits are exceeded, an engineered design shall be provided in accordance with the *Florida Building Code, Building* for the overall wind force resisting systems.

**R301.4 Dead load.** The actual weights of materials and construction shall be used for determining dead load with consideration for the dead load of fixed service *equipment*.

**R301.5 Live load.** The minimum uniformly distributed live load shall be as provided in Table R301.5.

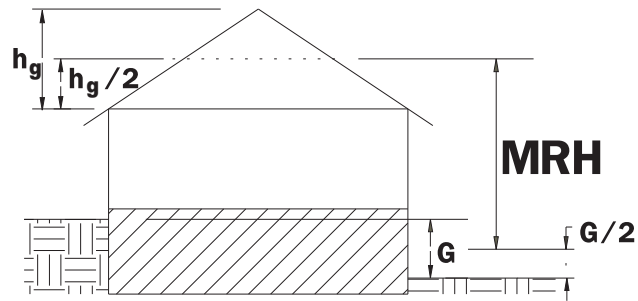

DETERMINING NUMBER OF STORIES ABOVE THE FOUNDATION		
O N E  S T O R Y		
T W O  S T O R Y		
T H R E E  S T O R Y		
- Foundation MRH - Measured from average grade		

Courtesy, American Forest and Paper Association, Washington, D.C.

For SI: 1 foot = 304.8 mm, 1 degree = 0.0175 rad.

NOTE: a = 4 feet in all cases.

FIGURE R301.3  
DETERMINING NUMBER OF STORIES ABOVE THE FOUNDATION

**TABLE R301.5**  
**MINIMUM UNIFORMLY DISTRIBUTED LIVE LOADS**  
**(in pounds per square foot)**

USE	LIVE LOAD
Attics without storage <sup>b</sup>	10
Attics with limited storage <sup>b, g</sup>	20
Habitable attics and attics served with fixed stairs	30
Balconies (exterior) and decks <sup>e</sup>	40
Fire escapes	40
Guardrails and handrails <sup>d</sup>	200 <sup>h</sup>
Guardrail in-fill components <sup>f</sup>	50 <sup>h</sup>
Passenger vehicle garages <sup>a</sup>	50 <sup>a</sup>
Rooms other than sleeping room	40
Sleeping rooms	30
Stairs	40 <sup>c</sup>

For SI: 1 pound per square foot = 0.0479 kPa, 1 square inch = 645 mm<sup>2</sup>, 1 pound = 4.45 N.

- a. Elevated garage floors shall be capable of supporting a 2,000-pound load applied over a 20-square-inch area.
- b. Attics without storage are those where the maximum clear height between joist and rafter is less than 42 inches, or where there are not two or more adjacent trusses with the same web configuration capable of containing a rectangle 42 inches high by 2 feet wide, or greater, located within the plane of the truss. For attics without storage, this live load need not be assumed to act concurrently with any other live load requirements.
- c. Individual stair treads shall be designed for the uniformly distributed live load or a 300-pound concentrated load acting over an area of 4 square inches, whichever produces the greater stresses.
- d. A single concentrated load applied in any direction at any point along the top.
- e. See Section R502.1.4 for decks attached to exterior walls.
- f. Guard in-fill components (all those except the handrail), balusters and panel fillers shall be designed to withstand a horizontally applied normal load of 50 pounds on an area equal to 1 square foot. This load need not be assumed to act concurrently with any other live load requirement.
- g. For attics with limited storage and constructed with trusses, this live load need be applied only to those portions of the bottom chord where there are two or more adjacent trusses with the same web configuration capable of containing a rectangle 42 inches high or greater by 2 feet wide or greater, located within the plane of the truss. The rectangle shall fit between the top of the bottom chord and the bottom of any other truss member, provided that each of the following criteria is met.
  1. The attic area is accessible by a pull-down stairway or framed opening in accordance with Section R807.1.
  2. The truss has a bottom chord pitch less than 2:12.
  3. Required insulation depth is less than the bottom chord member depth.
 The bottom chords of trusses meeting the above criteria for limited storage shall be designed for the greater of the actual imposed dead load or 10 psf, uniformly distributed over the entire span.
- h. Glazing used in handrail assemblies and guards shall be designed with a safety factor of 4. The safety factor shall be applied to each of the concentrated loads applied to the top of the rail, and to the load on the in-fill components. These loads shall be determined independent of one another, and loads are assumed not to occur with any other live load.

**R301.6 Roof load.** The roof shall be designed for the live load indicated in Table R301.6.

**TABLE R301.6**  
**MINIMUM ROOF LIVE LOADS IN POUNDS-FORCE**  
**PER SQUARE FOOT OF HORIZONTAL PROJECTION**

ROOF SLOPE	TRIBUTARY LOADED AREA IN SQUARE FEET FOR ANY STRUCTURAL MEMBER		
	0 to 200	201 to 600	Over 600
Flat or rise less than 4 inches per foot (1:3)	20	16	12
Rise 4 inches per foot (1:3) to less than 12 inches per foot (1:1)	16	14	12
Rise 12 inches per foot (1:1) and greater	12	12	12

For SI: 1 square foot = 0.0929 m<sup>2</sup>, 1 pound per square foot = 0.0479 kPa, 1 inch per foot = 83.3 mm/m.

**R301.7 Deflection.** The allowable deflection of any structural member under the live load listed in Sections R301.5 and R301.6 shall not exceed the values in Table R301.7.

**TABLE R301.7**  
**ALLOWABLE DEFLECTION OF STRUCTURAL MEMBERS<sup>a, b, c, d, e</sup>**

STRUCTURAL MEMBER	ALLOWABLE DEFLECTION
Rafters having slopes greater than 3:12 with no finished ceiling attached to rafters	L/180
Interior walls and partitions	H/180
Floors and plastered ceilings	L/360
All other structural members	L/240
Exterior walls with plaster or stucco finish	H/360
Exterior walls—wind loads <sup>a</sup> with brittle finishes	H/240
Exterior walls—wind loads <sup>a</sup> with flexible finishes	L/120 <sup>d</sup>
Lintels supporting masonry veneer walls <sup>e</sup>	L/600

**Note:** L = span length, H = span height.

- a. The wind load, when determined in accordance with ASCE 7 or Table R301.2(2), shall be permitted to be taken as 0.42 times the Component and Cladding loads for the purpose of the determining deflection limits herein.
- b. For cantilever members, L shall be taken as twice the length of the cantilever.
- c. For aluminum structural members or panels used in roofs or walls of sunroom additions or patio covers, not supporting edge of glass or sandwich panels, the total load deflection shall not exceed L/60. For continuous aluminum structural members supporting edge of glass, the total load deflection shall not exceed L/175 for each glass lite or L/60 for the entire length of the member, whichever is more stringent. For sandwich panels used in roofs or walls of sunroom additions or patio covers, the total load deflection shall not exceed L/120.
- d. Deflection for exterior walls with interior gypsum board finish shall be limited to an allowable deflection of H/180.
- e. Refer to Section R703.7.2.

**R301.8 Nominal sizes.** For the purposes of this code, where dimensions of lumber are specified, they shall be deemed to be nominal dimensions unless specifically designated as actual dimensions.

**SECTION R302  
FIRE-RESISTANT CONSTRUCTION**

**R302.1 Exterior walls.** Construction, projections, openings and penetrations of *exterior walls of dwellings* and accessory buildings shall comply with Table R302.1.

**Exceptions:**

1. Walls, projections, openings or penetrations in walls perpendicular to the line used to determine the *fire separation distance*.
2. Walls of *dwellings* and *accessory structures* located on the same *lot*.
3. Detached tool sheds and storage sheds, playhouses and similar structures are not required to provide wall protection based on location on the *lot*. Projections beyond the *exterior wall* shall not extend over the *lot line*.
4. Detached garages accessory to a *dwelling* located within 2 feet (610 mm) of a *lot line* are permitted to have roof eave projections not exceeding 4 inches (102 mm).
5. Foundation vents installed in compliance with this code are permitted.
6. Openings and roof overhang projections shall be permitted on the exterior wall of a building located on a zero lot line when the building exterior wall is separated from an adjacent building exterior wall by a distance of 6 feet or more, and the roof overhang projection is separated from an adjacent building projection by a distance of 4 feet or more, with 1 hour fire resistive construction on the underside of the overhang required, unless the separation between projections is 6 feet or more.
7. Screen enclosure walls of insect screening with a maximum of 25 percent solid flexible finishes.

**R302.2 Townhouses.** Each *townhouse* shall be considered a separate building and shall be separated by fire-resistance-

rated wall assemblies meeting the requirements of Section R302.1 for exterior walls.

**Exception:** A common 2-hour fire-resistance-rated wall assembly tested in accordance with ASTM E 119 or UL 263 is permitted for townhouses if such walls do not contain plumbing or mechanical equipment, ducts or vents in the cavity of the common wall, unless such materials and methods of penetration comply with Section R302.4. The wall shall be rated for fire exposure from both sides and shall extend to and be tight against exterior walls and the underside of the roof sheathing. Electrical installations shall be installed in accordance with Chapter 34. Penetrations of electrical outlet boxes shall be in accordance with Section R302.4.

**R302.2.1 Continuity.** The fire-resistance-rated wall or assembly separating *townhouses* shall be continuous from the foundation to the underside of the roof sheathing, deck or slab. The fire-resistance rating shall extend the full length of the wall or assembly, including wall extensions through and separating attached enclosed *accessory structures*.

**R302.2.2 Parapets.** Parapets constructed in accordance with Section R302.2.3 shall be provided for townhouses as an extension of exterior walls or common walls in accordance with the following:

1. Where roof surfaces adjacent to the wall or walls are at the same elevation, the parapet shall extend not less than 30 inches (762 mm) above the roof surfaces.
2. Where roof surfaces adjacent to the wall or walls are at different elevations and the higher roof is not more than 30 inches (762 mm) above the lower roof, the parapet shall extend not less than 30 inches (762 mm) above the lower roof surface.

**Exception:** A parapet is not required in the two cases above when the roof is covered with a minimum class C roof covering, and the roof decking or sheathing is of noncombustible materials or approved fire-retardant-treated wood for a distance of 4 feet (1219 mm) on

**TABLE R302.1  
EXTERIOR WALLS**

EXTERIOR WALL ELEMENT		MINIMUM FIRE-RESISTANCE RATING	MINIMUM FIRE SEPARATION DISTANCE
Walls	(Fire-resistance rated)	1 hour-tested in accordance with ASTM E 119 or UL 263 with exposure from both sides	0 feet
	(Not fire-resistance rated)	0 hours	3 feet
Projections	(Fire-resistance rated)	1 hour on the underside	2 feet
	(Not fire-resistance rated)	0 hours	3 feet
Openings in walls	Not allowed	N/A	N/A
	Unlimited	0 hours	3 feet
Penetrations	All	Comply with Section R302.4	< 3 feet
		None required	3 feet

For SI: 1 foot = 304.8 mm.  
N/A = Not Applicable.

each side of the wall or walls, or one layer of  $\frac{5}{8}$ -inch (15.9 mm) Type X gypsum board is installed directly beneath the roof decking or sheathing, supported by a minimum of nominal 2-inch (51 mm) ledgers attached to the sides of the roof framing members, for a minimum distance of 4 feet (1220 mm) on each side of the wall or walls.

3. A parapet is not required where roof surfaces adjacent to the wall or walls are at different elevations and the higher roof is more than 30 inches (762 mm) above the lower roof. The common wall construction from the lower roof to the underside of the higher roof deck shall not have less than a 1-hour fire-resistive rating. The wall shall be rated for exposure from both sides.

**R302.2.3 Parapet construction.** Parapets shall have the same fire-resistance rating as that required for the supporting wall or walls. On any side adjacent to a roof surface, the parapet shall have noncombustible faces for the uppermost 30 inches (762 mm), to include counterflashing and coping materials. Where the roof slopes toward a parapet at slopes greater than two units vertical in 12 units horizontal (16.7-percent slope), the parapet shall extend to the same height as any portion of the roof within a distance of 3 feet (914 mm), but in no case shall the height be less than 30 inches (762 mm).

**R302.2.4 Structural independence.** Each individual *townhouse* shall be structurally independent.

**Exceptions:**

1. Foundations supporting *exterior walls* or common walls.
2. Structural roof and wall sheathing from each unit may fasten to the common wall framing.
3. Nonstructural wall and roof coverings.
4. Flashing at termination of roof covering over common wall.
5. *Townhouses* separated by a common 1-hour fire-resistance-rated wall as provided in Section R302.2.

**R302.3 Two-family dwellings.** *Dwelling units* in two-family dwellings shall be separated from each other by wall and/or floor assemblies having not less than a 1-hour fire-resistance rating when tested in accordance with ASTM E 119 or UL 263. Fire-resistance-rated floor-ceiling and wall assemblies shall extend to and be tight against the *exterior wall*, and wall assemblies shall extend from the foundation to the underside of the roof sheathing.

**Exceptions:**

1. A fire-resistance rating of  $\frac{1}{2}$  hour shall be permitted in buildings equipped throughout with an automatic sprinkler system installed in accordance with NFPA 13.
2. Wall assemblies need not extend through *attic* spaces when the ceiling is protected by not less than  $\frac{5}{8}$ -inch (15.9 mm) Type X gypsum board and an *attic* draft stop constructed as specified in Section R302.12.1 is provided above and along the wall assembly separating the *dwellings*. The structural framing supporting

the ceiling shall also be protected by not less than  $\frac{1}{2}$ -inch (12.7 mm) gypsum board or equivalent.

3. Screen enclosure walls of insect screening with a maximum of 25 percent solid flexible finishes.

**R302.3.1 Supporting construction.** When floor assemblies are required to be fire-resistance rated by Section R302.3, the supporting construction of such assemblies shall have an equal or greater fire-resistance rating.

**R302.4 Dwelling unit rated penetrations.** Penetrations of wall or floor/ceiling assemblies required to be fire-resistance rated in accordance with Section R302.2 or R302.3 shall be protected in accordance with this section.

**R302.4.1 Through penetrations.** Through penetrations of fire-resistance-rated wall or floor assemblies shall comply with Section R302.4.1.1 or R302.4.1.2.

**Exception:** Where the penetrating items are steel, ferrous or copper pipes, tubes or conduits, the annular space shall be protected as follows:

1. In concrete or masonry wall or floor assemblies, concrete, grout or mortar shall be permitted where installed to the full thickness of the wall or floor assembly or the thickness required to maintain the fire-resistance rating, provided:
  - 1.1. The nominal diameter of the penetrating item is a maximum of 6 inches (152 mm); and
  - 1.2. The area of the opening through the wall does not exceed 144 square inches (92 900 mm<sup>2</sup>).
2. The material used to fill the annular space shall prevent the passage of flame and hot gases sufficient to ignite cotton waste where subjected to ASTM E 119 or UL 263 time temperature fire conditions under a minimum positive pressure differential of 0.01 inch of water (3 Pa) at the location of the penetration for the time period equivalent to the fire resistance rating of the construction penetrated.

**R302.4.1.1 Fire-resistance-rated assembly.** Penetrations shall be installed as tested in the *approved* fire-resistance-rated assembly.

**R302.4.1.2 Penetration firestop system.** Penetrations shall be protected by an *approved* penetration firestop system installed as tested in accordance with ASTM E 814 or UL 1479, with a minimum positive pressure differential of 0.01 inch of water (3 Pa) and shall have an F rating of not less than the required fire-resistance rating of the wall or floor/ceiling assembly penetrated.

**R302.4.2 Membrane penetrations.** Membrane penetrations shall comply with Section R302.4.1. Where walls are required to have a fire-resistance rating, recessed fixtures shall be installed so that the required fire-resistance rating will not be reduced.

**Exceptions:**

1. Membrane penetrations of maximum 2-hour fire-resistance-rated walls and partitions by steel



electrical boxes that do not exceed 16 square inches (0.0103 m<sup>2</sup>) in area provided the aggregate area of the openings through the membrane does not exceed 100 square inches (0.0645 m<sup>2</sup>) in any 100 square feet (9.29 m<sup>2</sup>) of wall area. The annular space between the wall membrane and the box shall not exceed 1/8 inch (3.1 mm). Such boxes on opposite sides of the wall shall be separated by one of the following:

- 1.1. By a horizontal distance of not less than 24 inches (610 mm) where the wall or partition is constructed with individual noncommunicating stud cavities;
  - 1.2. By a horizontal distance of not less than the depth of the wall cavity when the wall cavity is filled with cellulose loose-fill, rockwool or slag mineral wool insulation;
  - 1.3. By solid fire blocking in accordance with Section R302.11;
  - 1.4. By protecting both boxes with listed putty pads; or
  - 1.5. By other listed materials and methods.
2. Membrane penetrations by listed electrical boxes of any materials provided the boxes have been tested for use in fire-resistance-rated assemblies and are installed in accordance with the instructions included in the listing. The annular space between the wall membrane and the box shall not exceed 1/8 inch (3.1 mm) unless listed otherwise. Such boxes on opposite sides of the wall shall be separated by one of the following:
- 2.1. By the horizontal distance specified in the listing of the electrical boxes;
  - 2.2. By solid fireblocking in accordance with Section R302.11;
  - 2.3. By protecting both boxes with listed putty pads; or
  - 2.4. By other listed materials and methods.
3. The annular space created by the penetration of a fire sprinkler provided it is covered by a metal escutcheon plate.

**R302.5 Dwelling/garage opening/penetration protection.** Openings and penetrations through the walls or ceilings separating the *dwelling* from the garage shall be in accordance with Sections R302.5.1 through R302.5.3.

**R302.5.1 Opening protection.** Openings from a private garage directly into a room used for sleeping purposes shall not be permitted. Other openings between the garage and residence shall be equipped with solid wood doors not less than 1 3/8 inches (35 mm) in thickness, solid or honeycomb core steel doors not less than 1 3/8 inches (35 mm) thick, or 20-minute fire-rated doors.

**R302.5.2 Duct penetration.** Ducts in the garage and ducts penetrating the walls or ceilings separating the *dwelling* from the garage shall be constructed of a minimum No. 26 gage (0.48 mm) sheet steel, 1 inch minimum rigid nonmetallic Class 0 or Class 1 duct board, or other *approved* material and shall have no openings into the garage.

**R302.5.3 Other penetrations.** Penetrations through the separation required in Section R302.6 shall be protected as required by Section R302.11, Item 4.

**R302.6 Dwelling/garage fire separation.** The garage shall be separated as required by Table R302.6. Openings in garage walls shall comply with Section R302.5. This provision does not apply to garage walls that are perpendicular to the adjacent *dwelling unit* wall.

**R302.7 Under-stair protection.** Enclosed accessible space under stairs shall have walls, under-stair surface and any soffits protected on the enclosed side with 1/2-inch (12.7 mm) gypsum board.

**R302.8 Foam plastics.** For requirements for foam plastics see Section R316.

**R302.9 Flame spread index and smoke-developed index for wall and ceiling finishes.** Flame spread and smoke index for wall and ceiling finishes shall be in accordance with Sections R302.9.1 through R302.9.4.

**R302.9.1 Flame spread index.** Wall and ceiling finishes shall have a flame spread index of not greater than 200.

**Exception:** Flame spread index requirements for finishes shall not apply to trim defined as picture molds, chair rails, baseboards and handrails; to doors and windows or their frames; or to materials that are less than 1/28 inch (0.91 mm) in thickness cemented to the surface of walls or ceilings if these materials exhibit flame spread

**TABLE R302.6  
DWELLING/GARAGE SEPARATION**

SEPARATION	MATERIAL
From the residence and attics	Not less than 1/2-inch gypsum board or equivalent applied to the garage side
From all habitable rooms above the garage	Not less than 5/8-inch Type X gypsum board or equivalent
Structure(s) supporting floor/ceiling assemblies used for separation required by this section	Not less than 1/2-inch gypsum board or equivalent
Garages located less than 3 feet from a dwelling unit on the same lot	Not less than 1/2-inch gypsum board or equivalent applied to the interior side of exterior walls that are within this area

For SI: 1 inch = 25.4 mm, 1 foot = 304.8 mm.

index values no greater than those of paper of this thickness cemented to a noncombustible backing.

**R302.9.2 Smoke-developed index.** Wall and ceiling finishes shall have a smoke-developed index of not greater than 450.

**R302.9.3 Testing.** Tests shall be made in accordance with ASTM E 84 or UL 723.

**R302.9.4 Alternate test method.** As an alternate to having a flame-spread index of not greater than 200 and a smoke developed index of not greater than 450 when tested in accordance with ASTM E 84 or UL 723, wall and ceiling finishes, other than textiles, shall be permitted to be tested in accordance with NFPA 286. Materials tested in accordance with NFPA 286 shall meet the following criteria:

During the 40 kW exposure, the interior finish shall comply with Item 1. During the 160 kW exposure, the interior finish shall comply with Item 2. During the entire test, the interior finish shall comply with Item 3.

1. During the 40 kW exposure, flames shall not spread to the ceiling.
2. During the 160 kW exposure, the interior finish shall comply with the following:
  - 2.1. Flame shall not spread to the outer extremity of the sample on any wall or ceiling.
  - 2.2. Flashover, as defined in NFPA 286, shall not occur.
3. The total smoke released throughout the NFPA 286 test shall not exceed 1,000 m<sup>2</sup>.

**R302.10 Flame spread index and smoke developed index for insulation.** Flame spread and smoke developed index for insulation shall be in accordance with Sections R302.10.1 through R302.10.5.

**R302.10.1 Insulation.** Insulation materials, including facings, such as vapor retarders and vapor-permeable membranes installed within floor-ceiling assemblies, roof-ceiling assemblies, wall assemblies, crawl spaces and *attics* shall have a flame spread index not to exceed 25 with an accompanying smoke-developed index not to exceed 450 when tested in accordance with ASTM E 84 or UL 723.

**Exceptions:**

1. When such materials are installed in concealed spaces, the flame spread index and smoke-developed index limitations do not apply to the facings, provided that the facing is installed in substantial contact with the unexposed surface of the ceiling, floor or wall finish.
2. Cellulose loose-fill insulation, which is not spray applied, complying with the requirements of Section R302.10.3, shall only be required to meet the smoke-developed index of not more than 450.

**R302.10.2 Loose-fill insulation.** Loose-fill insulation materials that cannot be mounted in the ASTM E 84 or UL 723 apparatus without a screen or artificial supports shall comply with the flame spread and smoke-developed limits

of Section R302.10.1 when tested in accordance with CAN/ULC S102.2.

**Exception:** Cellulose loose-fill insulation shall not be required to be tested in accordance with CAN/ULC S102.2, provided such insulation complies with the requirements of Section R302.10.1 and Section R302.10.3.

**R302.10.3 Cellulose loose-fill insulation.** Cellulose loose-fill insulation shall comply with CPSC 16 CFR, Parts 1209 and 1404. Each package of such insulating material shall be clearly *labeled* in accordance with CPSC 16 CFR, Parts 1209 and 1404.

**R302.10.4 Exposed attic insulation.** All exposed insulation materials installed on *attic* floors shall have a critical radiant flux not less than 0.12 watt per square centimeter. Exposed foam plastic insulation materials exposed on the underside of the roof deck or on the attic walls shall comply with Section R316.

**R302.10.5 Testing.** Tests for critical radiant flux shall be made in accordance with ASTM E 970.

**R302.11 Fireblocking.** In combustible construction, fireblocking shall be provided to cut off all concealed draft openings (both vertical and horizontal) and to form an effective fire barrier between stories, and between a top *story* and the roof space.

Fireblocking shall be provided in wood-frame construction in the following locations:

1. In concealed spaces of stud walls and partitions, including furred spaces and parallel rows of studs or staggered studs, as follows:
  - 1.1. Vertically at the ceiling and floor levels.
  - 1.2. Horizontally at intervals not exceeding 10 feet (3048 mm).
2. At all interconnections between concealed vertical and horizontal spaces such as occur at soffits, drop ceilings and cove ceilings.
3. In concealed spaces between stair stringers at the top and bottom of the run. Enclosed spaces under stairs shall comply with Section R302.7.
4. At openings around vents, pipes, ducts, cables and wires at ceiling and floor level, with an *approved* material to resist the free passage of flame and products of combustion. The material filling this annular space shall not be required to meet the ASTM E 136 requirements.
5. For the fireblocking of chimneys and fireplaces, see Section R1003.19.
6. Fireblocking of cornices of a two-family *dwelling* is required at the line of *dwelling unit* separation.

**R302.11.1 Fireblocking materials.** Except as provided in Section R302.11, Item 4, fireblocking shall consist of the following materials.

1. Two-inch (51 mm) nominal lumber.
2. Two thicknesses of 1-inch (25.4 mm) nominal lumber with broken lap joints.

3. One thickness of  $2\frac{3}{32}$ -inch (18.3 mm) wood structural panels with joints backed by  $2\frac{3}{32}$ -inch (18.3 mm) wood structural panels.
4. One thickness of  $\frac{3}{4}$ -inch (19.1 mm) particleboard with joints backed by  $\frac{3}{4}$ -inch (19.1 mm) particleboard.
5. One-half-inch (12.7 mm) gypsum board.
6. One-quarter-inch (6.4 mm) cement-based millboard.
7. Batts or blankets of mineral wool or glass fiber or other *approved* materials installed in such a manner as to be securely retained in place.

**R302.11.1.1 Batts or blankets of mineral or glass fiber.** Batts or blankets of mineral or glass fiber or other *approved* nonrigid materials shall be permitted for compliance with the 10-foot (3048 mm) horizontal fireblocking in walls constructed using parallel rows of studs or staggered studs.

**R302.11.1.2 Unfaced fiberglass.** Unfaced fiberglass batt insulation used as fireblocking shall fill the entire cross section of the wall cavity to a minimum height of 16 inches (406 mm) measured vertically. When piping, conduit or similar obstructions are encountered, the insulation shall be packed tightly around the obstruction.

**R302.11.1.3 Loose-fill insulation material.** Loose-fill insulation material shall not be used as a fireblock unless specifically tested in the form and manner intended for use to demonstrate its ability to remain in place and to retard the spread of fire and hot gases.

**R302.11.2 Fireblocking integrity.** The integrity of all fireblocks shall be maintained.

**R302.12 Draftstopping.** In combustible construction where there is usable space both above and below the concealed space of a floor/ceiling assembly, draftstops shall be installed so that the area of the concealed space does not exceed 1,000 square feet (92.9 m<sup>2</sup>). Draftstopping shall divide the concealed space into approximately equal areas. Where the assembly is enclosed by a floor membrane above and a ceiling membrane below, draftstopping shall be provided in floor/ceiling assemblies under the following circumstances:

1. Ceiling is suspended under the floor framing.
2. Floor framing is constructed of truss-type open-web or perforated members.

**R302.12.1 Materials.** Draftstopping materials shall not be less than  $\frac{1}{2}$ -inch (12.7 mm) gypsum board,  $\frac{3}{8}$ -inch (9.5 mm) wood structural panels or other *approved* materials adequately supported. Draftstopping shall be installed parallel to the floor framing members unless otherwise *approved* by the *building official*. The integrity of the draftstops shall be maintained.

**R302.13 Combustible insulation clearance.** Combustible insulation shall be separated a minimum of 3 inches (76 mm) from recessed luminaires, fan motors and other heat-producing devices.

**Exception:** Where heat-producing devices are listed for lesser clearances, combustible insulation complying with

the listing requirements shall be separated in accordance with the conditions stipulated in the listing.

Recessed luminaires installed in the *building thermal envelope* shall meet the requirements of the *Florida Building Code, Energy Conservation*.

## SECTION R303 LIGHT, VENTILATION AND HEATING

**R303.1 Habitable rooms.** All habitable rooms shall have an aggregate glazing area of not less than 8 percent of the floor area of such rooms. Natural *ventilation* shall be through windows, doors, louvers or other *approved* openings to the outdoor air. Such openings shall be provided with ready access or shall otherwise be readily controllable by the building occupants. The minimum openable area to the outdoors shall be 4 percent of the floor area being ventilated.

### Exceptions:

1. The glazed areas need not be openable where the opening is not required by Section R310 and an *approved* mechanical *ventilation* system capable of producing 0.35 air change per hour in the room is installed or a whole-house mechanical *ventilation* system is installed capable of supplying outdoor *ventilation* air of 15 cubic feet per minute (cfm) (78 L/s) per occupant computed on the basis of two occupants for the first bedroom and one occupant for each additional bedroom.
2. The glazed areas need not be installed in rooms where Exception 1 above is satisfied and artificial light is provided capable of producing an average illumination of 6 footcandles (65 lux) over the area of the room at a height of 30 inches (762 mm) above the floor level.
3. Use of sunroom *additions* and patio covers, as defined in Section R202, shall be permitted for natural *ventilation* if in excess of 40 percent of the exterior sunroom walls are open, or are enclosed only by insect screening.

**R303.2 Adjoining rooms.** For the purpose of determining light and *ventilation* requirements, any room shall be considered as a portion of an adjoining room when at least one-half of the area of the common wall is open and unobstructed and provides an opening of not less than one-tenth of the floor area of the interior room but not less than 25 square feet (2.3 m<sup>2</sup>).

**Exception:** Openings required for light and/or *ventilation* shall be permitted to open into a thermally isolated sunroom *addition* or patio cover, provided that there is an openable area between the adjoining room and the sunroom *addition* or patio cover of not less than one-tenth of the floor area of the interior room but not less than 20 square feet (2 m<sup>2</sup>). The minimum openable area to the outdoors shall be based upon the total floor area being ventilated.

**R303.3 Bathrooms.** Bathrooms, water closet compartments and other similar rooms shall be provided with aggregate glazing area in windows of not less than 3 square feet (0.3 m<sup>2</sup>), one-half of which must be openable.

**Exception:** The glazed areas shall not be required where artificial light and a mechanical *ventilation* system are provided.

The minimum *ventilation* rates shall be 50 cubic feet per minute (24 L/s) for intermittent *ventilation* or 20 cubic feet per minute (10 L/s) for continuous *ventilation*. *Ventilation* air from the space shall be exhausted directly to the outside.

**R303.4 Opening location.** Outdoor intake and exhaust openings shall be located in accordance with Sections R303.4.1 and R303.4.2.

**R303.4.1 Intake openings.** Mechanical and gravity outdoor air intake openings shall be located a minimum of 10 feet (3048 mm) from any hazardous or noxious contaminant, such as vents, chimneys, plumbing vents, streets, alleys, parking lots and loading docks, except as otherwise specified in this code. Where a source of contaminant is located within 10 feet (3048 mm) of an intake opening, such opening shall be located a minimum of 2 feet (610 mm) below the contaminant source.

For the purpose of this section, the exhaust from *dwelling* unit toilet rooms, bathrooms and kitchens shall not be considered as hazardous or noxious.

**R303.4.2 Exhaust openings.** Exhaust air shall not be directed onto walkways.

**R303.5 Outside opening protection.** Air exhaust and intake openings that terminate outdoors shall be protected with corrosion-resistant screens, louvers or grilles having a minimum opening size of  $\frac{1}{4}$  inch (6 mm) and a maximum opening size of  $\frac{1}{2}$  inch (13 mm), in any dimension. Openings shall be protected against local weather conditions. Outdoor air exhaust and intake openings shall meet the provisions for *exterior wall* opening protectives in accordance with this code.

**R303.6 Stairway illumination.** All interior and exterior stairways shall be provided with a means to illuminate the stairs, including the landings and treads. Interior stairways shall be provided with an artificial light source located in the immediate vicinity of each landing of the stairway. For interior stairs the artificial light sources shall be capable of illuminating treads and landings to levels not less than 1 foot-candle (11 lux) measured at the center of treads and landings. Exterior stairways shall be provided with an artificial light source located in the immediate vicinity of the top landing of the stairway. Exterior stairways providing access to a *basement* from the outside *grade* level shall be provided with an artificial light source located in the immediate vicinity of the bottom landing of the stairway.

**Exception:** An artificial light source is not required at the top and bottom landing, provided an artificial light source is located directly over each stairway section.

**R303.6.1 Light activation.** Where lighting outlets are installed in interior stairways, there shall be a wall switch at each floor level to control the lighting outlet where the stairway has six or more risers. The illumination of exterior stairways shall be controlled from inside the *dwelling* unit.

**Exception:** Lights that are continuously illuminated or automatically controlled.

**R303.7 Required glazed openings.** Required glazed openings shall open directly onto a street or public alley, or a *yard* or court located on the same *lot* as the building.

**Exceptions:**

1. Required glazed openings may face into a roofed porch where the porch abuts a street, *yard* or court and the longer side of the porch is at least 65 percent unobstructed and the ceiling height is not less than 7 feet (2134 mm).
2. Eave projections shall not be considered as obstructing the clear open space of a *yard* or court.
3. Required glazed openings may face into the area under a deck, balcony, bay or floor cantilever provided a clear vertical space at least 36 inches (914 mm) in height is provided.

**R303.7.1 Sunroom additions.** Required glazed openings shall be permitted to open into sunroom *additions* or patio covers that abut a street, *yard* or court if in excess of 40 percent of the exterior sunroom walls are open, or are enclosed only by insect screening, and the ceiling height of the sunroom is not less than 7 feet (2134 mm).

**R303.8 Required heating.** When the winter design temperature in Table R301.2(1) is below 60°F (16°C), every *dwelling unit* shall be provided with heating facilities capable of maintaining a minimum room temperature of 68°F (20°C) at a point 3 feet (914 mm) above the floor and 2 feet (610 mm) from exterior walls in all habitable rooms at the design temperature. The installation of one or more portable space heaters shall not be used to achieve compliance with this section.

## SECTION R304 MINIMUM ROOM AREAS

**R304.1 Minimum area.** Every *dwelling* unit shall have at least one habitable room that shall have not less than 120 square feet (11 m<sup>2</sup>) of gross floor area.

**R304.2 Other rooms.** Other habitable rooms shall have a floor area of not less than 70 square feet (6.5 m<sup>2</sup>).

**Exception:** Kitchens.

**R304.3 Minimum dimensions.** Habitable rooms shall not be less than 7 feet (2134 mm) in any horizontal dimension.

**Exception:** Kitchens.

**R304.4 Height effect on room area.** Portions of a room with a sloping ceiling measuring less than 5 feet (1524 mm) or a furred ceiling measuring less than 7 feet (2134 mm) from the finished floor to the finished ceiling shall not be considered as contributing to the minimum required habitable area for that room.

## SECTION R305 CEILING HEIGHT

**R305.1 Minimum height.** *Habitable space*, hallways, bathrooms, toilet rooms, laundry rooms and portions of *basements*

containing these spaces shall have a ceiling height of not less than 7 feet (2134 mm).

**Exceptions:**

1. For rooms with sloped ceilings, at least 50 percent of the required floor area of the room must have a ceiling height of at least 7 feet (2134 mm) and no portion of the required floor area may have a ceiling height of less than 5 feet (1524 mm).
2. Bathrooms shall have a minimum ceiling height of 6 feet 8 inches (2032 mm) at the center of the front clearance area for fixtures as shown in Figure R307.1. The ceiling height above fixtures shall be such that the fixture is capable of being used for its intended purpose. A shower or tub equipped with a showerhead shall have a minimum ceiling height of 6 feet 8 inches (2032 mm) above a minimum area 30 inches (762 mm) by 30 inches (762 mm) at the showerhead.

**R305.1.1 Basements.** Portions of *basements* that do not contain *habitable space*, hallways, bathrooms, toilet rooms and laundry rooms shall have a ceiling height of not less than 6 feet 8 inches (2032 mm).

**Exception:** Beams, girders, ducts or other obstructions may project to within 6 feet 4 inches (1931 mm) of the finished floor.

**SECTION R306  
SANITATION**

**R306.1 Toilet facilities.** Every *dwelling* unit shall be provided with a water closet, lavatory, and a bathtub or shower.

**R306.2 Kitchen.** Each *dwelling* unit shall be provided with a kitchen area and every kitchen area shall be provided with a sink.

**R306.3 Sewage disposal.** All plumbing fixtures shall be connected to a sanitary sewer or to an *approved* private sewage disposal system in accordance with Chapter 64E-6, *Florida Administrative Code*, Standards for Onsite Sewage Treatment and Disposal Systems..

**R306.4 Water supply to fixtures.** All plumbing fixtures shall be connected to an *approved* water supply. Kitchen sinks, lavatories, bathtubs, showers, bidets, laundry tubs and washing machine outlets shall be provided with hot and cold water.

**SECTION R307  
TOILET, BATH AND SHOWER SPACES**

**R307.1 Space required.** Fixtures shall be spaced in accordance with Figure R307.1, and in accordance with the requirements of Section P2705.1.

**R307.2 Bathtub and shower spaces.** Bathtub and shower floors and walls above bathtubs with installed shower heads and in shower compartments shall be finished with a

nonabsorbent surface. Such wall surfaces shall extend to a height of not less than 6 feet (1829 mm) above the floor.

**SECTION R308  
GLAZING**

**R308.1 Identification.** Each pane shall bear the manufacturer’s label designating the type and thickness of glass or glazing material. Except as indicated in Section R308.1.1, each pane of glazing installed in hazardous locations as defined in Section R308.4 shall be provided with a manufacturer’s or installer’s label, designating the type and thickness of glass and the safety glazing standard with which it complies, which is visible in the final installation. The safety glazing label shall be acid etched, sandblasted, ceramic-fired, embossed mark, or shall be of a type which once applied cannot be removed without being destroyed. Laminated glass, other than as used for safety glazing, shall be permanently identified as per this section, designating laminator, overall glass thickness and trade name of interlayer.

**Exceptions:**

1. For other than tempered glass, manufacturer’s designations are not required provided the *building official* approves the use of a certificate, affidavit or other evidence furnished by the glazing contractor certifying that each light is glazed in accordance with approved construction documents that comply with the provisions of this chapter confirming compliance with this code.
2. Tempered spandrel glass is permitted to be identified by the manufacturer with a removable paper label.

**R308.1.1 Identification of multiple assemblies.** Multipane assemblies having individual panes not exceeding 1 square foot (0.09 m<sup>2</sup>) in exposed area shall have at least one pane in the assembly identified in accordance with Section R308.1. All other panes in the assembly shall be *labeled* “CPSC 16 CFR 1201” or “ANSI Z97.1” as appropriate.

**R308.2 Louvered windows or jalousies.** Regular, float, wired or patterned glass in jalousies and louvered windows shall be no thinner than nominal 3/16 inch (5 mm) and no longer than 48 inches (1219 mm). Exposed glass edges shall be smooth.

**R308.2.1 Wired glass prohibited.** Wired glass with wire exposed on longitudinal edges shall not be used in jalousies or louvered windows.

**R308.3 Human impact loads.** Individual glazed areas, including glass mirrors in hazardous locations such as those indicated as defined in Section R308.4, shall pass the test requirements of Section R308.3.1.

**Exceptions:**

1. Louvered windows and jalousies shall comply with Section R308.2.
2. Mirrors and other glass panels mounted or hung on a surface that provides a continuous backing support.
3. Glass unit masonry complying with Section R610.

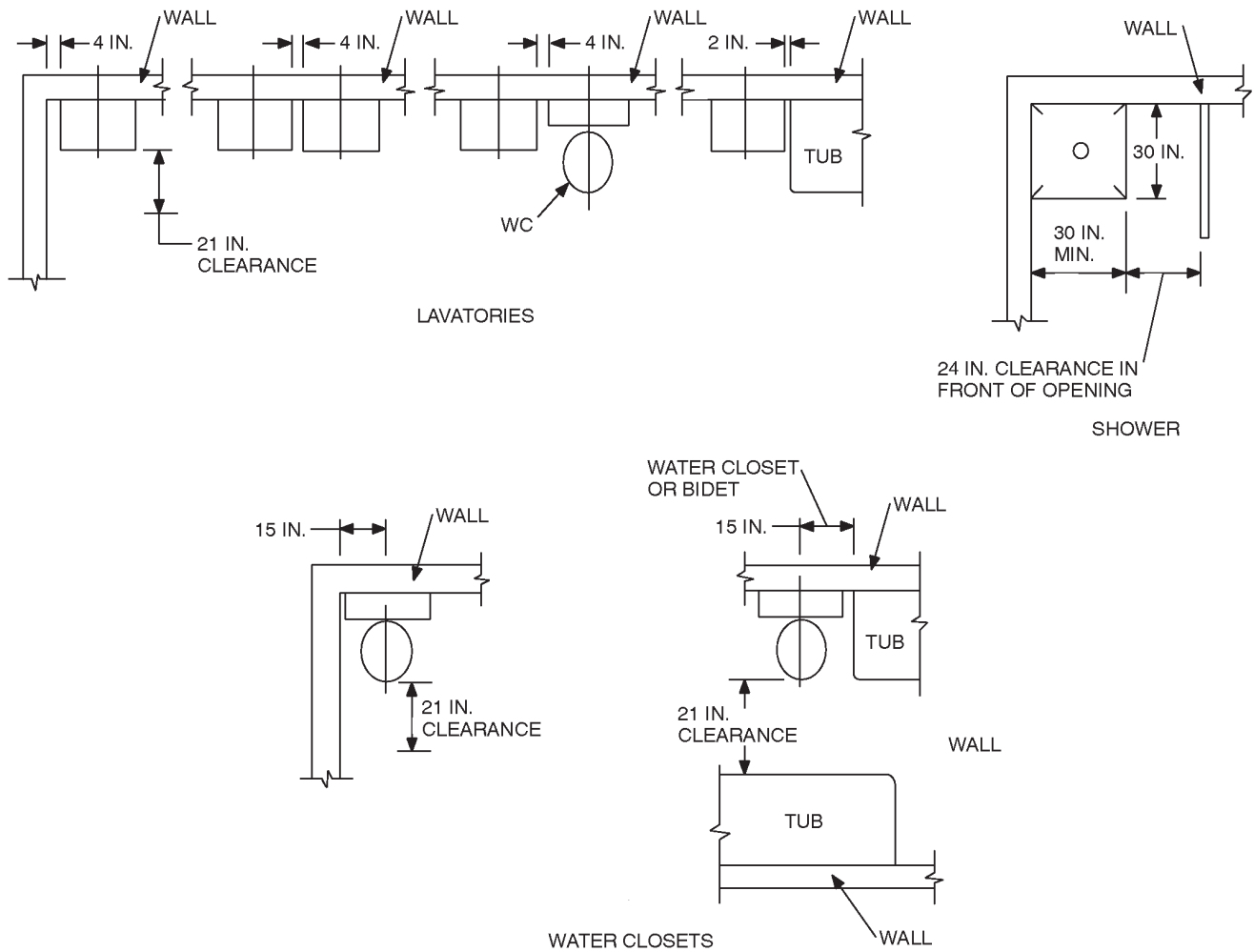

For SI: 1 inch = 25.4 mm.

**FIGURE R307.1**  
**MINIMUM FIXTURE CLEARANCES**

**R308.3.1 Impact test.** Where required by other sections of the code, glazing shall be tested in accordance with CPSC 16 CFR 1201. Glazing shall comply with the test criteria for Category I or II as indicated in Table R308.3.1(1).

**Exception:** Glazing not in doors or enclosures for hot tubs, whirlpools, saunas, steam rooms, bathtubs and showers shall be permitted to be tested in accordance with ANSI Z97.1. Glazing shall comply with the test criteria for Class A or B as indicated in Table R308.3.1 (2).

**R308.4 Hazardous locations.** The following shall be considered specific hazardous locations for the purposes of glazing:

1. Glazing in all fixed and operable panels of swinging, sliding and bifold doors.

**Exceptions:**

1. Glazed openings of a size through which a 3-inch diameter (76 mm) sphere is unable to pass.
2. Decorative glazing.

2. Glazing in an individual fixed or operable panel adjacent to a door where the nearest vertical edge is within a 24-inch (610 mm) arc of the door in a closed position and whose bottom edge is less than 60 inches (1524 mm) above the floor or walking surface.

**Exceptions:**

1. Decorative glazing.
2. When there is an intervening wall or other permanent barrier between the door and the glazing.
3. Glazing in walls on the latch side of and perpendicular to the plane of the door in a closed position.
4. Glazing adjacent to a door where access through the door is to a closet or storage area 3 feet (914 mm) or less in depth.

TABLE R308.3.1(1)  
MINIMUM CATEGORY CLASSIFICATION OF GLAZING USING CPSC 16 CFR 1201

EXPOSED SURFACE AREA OF ONE SIDE OF ONE LITE	GLAZING IN STORM OR COMBINATION DOORS (Category Class)	GLAZING IN DOORS (Category Class)	GLAZED PANELS REGULATED BY ITEM 7 OF SECTION R308.4 (Category Class)	GLAZED PANELS REGULATED BY ITEM 6 OF SECTION R308.4 (Category Class)	GLAZING IN DOORS AND ENCLOSURES REGULATED BY ITEM 5 OF SECTION R308.4 (Category Class)	SLIDING GLASS DOORS PATIO TYPE (Category Class)
9 square feet or less	I	I	NR	I	II	II
More than 9 square feet	II	II	II	II	II	II

For SI: 1 square foot = 0.0929 m<sup>2</sup>.  
NR means "No Requirement."

TABLE R308.3.1(2)  
MINIMUM CATEGORY CLASSIFICATION OF GLAZING USING ANSI Z97.1

EXPOSED SURFACE AREA OF ONE SIDE OF ONE LITE	GLAZED PANELS REGULATED BY ITEM 7 OF SECTION R308.4 (Category Class)	GLAZED PANELS REGULATED BY ITEM 6 OF SECTION R308.4 (Category Class)	DOORS AND ENCLOSURES REGULATED BY ITEM 5 OF SECTION R308.4 <sup>a</sup> (Category Class)
9 square feet or less	No requirement	B	A
More than 9 square feet	A	A	A

For SI: 1 square foot = 0.0929 m<sup>2</sup>.  
a. Use is permitted only by the exception to Section R308.3.1.

5. Glazing that is adjacent to the fixed panel of patio doors.
3. Glazing in an individual fixed or operable panel that meets all of the following conditions:
  - 3.1. The exposed area of an individual pane is larger than 9 square feet (0.836 m<sup>2</sup>); and
  - 3.2. The bottom edge of the glazing is less than 18 inches (457 mm) above the floor; and
  - 3.3. The top edge of the glazing is more than 36 inches (914 mm) above the floor; and
  - 3.4. One or more walking surfaces are within 36 inches (914 mm), measured horizontally and in a straight line, of the glazing.

**Exceptions:**

1. Decorative glazing.
2. When a horizontal rail is installed on the accessible side(s) of the glazing 34 to 38 inches (864 to 965) above the walking surface. The rail shall be capable of withstanding a horizontal load of 50 pounds per linear foot (730 N/m) without contacting the glass and be a minimum of 1½ inches (38 mm) in cross sectional height.
3. Outboard panes in insulating glass units and other multiple glazed panels when the bottom edge of the glass is 25 feet (7620 mm) or more above *grade*, a roof, walking surfaces or other horizontal [within 45 degrees (0.79 rad) of horizontal] surface adjacent to the glass exterior.

4. All glazing in railings regardless of area or height above a walking surface. Included are structural baluster panels and nonstructural infill panels.
5. Glazing in enclosures for or walls facing hot tubs, whirlpools, saunas, steam rooms, bathtubs and showers where the bottom exposed edge of the glazing is less than 60 inches (1524 mm) measured vertically above any standing or walking surface.
 

**Exception:** Glazing that is more than 60 inches (1524 mm), measured horizontally and in a straight line, from the waters edge of a hot tub, whirlpool or bathtub.
6. Glazing in walls and fences adjacent to indoor and outdoor swimming pools, hot tubs and spas where the bottom edge of the glazing is less than 60 inches (1524 mm) above a walking surface and within 60 inches (1524 mm), measured horizontally and in a straight line, of the water's edge. This shall apply to single glazing and all panes in multiple glazing.
7. Glazing adjacent to stairways, landings and ramps within 36 inches (914 mm) horizontally of a walking surface when the exposed surface of the glazing is less than 60 inches (1524 mm) above the plane of the adjacent walking surface.

**Exceptions:**

1. When a rail is installed on the accessible side(s) of the glazing 34 to 38 inches (864 to 965 mm) above the walking surface. The rail shall be capable of withstanding a horizontal load of 50 pounds per linear foot (730 N/m) without contacting the glass and be a minimum of 1½ inches (38 mm) in cross sectional height.

2. The side of the stairway has a guardrail or hand-rail, including balusters or in-fill panels, complying with Sections R311.7.7 and R312 and the plane of the glazing is more than 18 inches (457 mm) from the railing; or
  3. When a solid wall or panel extends from the plane of the adjacent walking surface to 34 inches (863 mm) to 36 inches (914 mm) above the walking surface and the construction at the top of that wall or panel is capable of withstanding the same horizontal load as a *guard*.
8. Glazing adjacent to stairways within 60 inches (1524 mm) horizontally of the bottom tread of a stairway in any direction when the exposed surface of the glazing is less than 60 inches (1524 mm) above the nose of the tread.

**Exceptions:**

1. The side of the stairway has a guardrail or hand-rail, including balusters or in-fill panels, complying with Sections R311.7.7 and R312 and the plane of the glass is more than 18 inches (457 mm) from the railing; or
2. When a solid wall or panel extends from the plane of the adjacent walking surface to 34 inches (864 mm) to 36 inches (914 mm) above the walking surface and the construction at the top of that wall or panel is capable of withstanding the same horizontal load as a *guard*.

**R308.5 Site built windows.** Site built windows shall comply with Section 2404 of the *Florida Building Code, Building*.

**R308.6 Skylights and sloped glazing.** Skylights and sloped glazing shall comply with the following sections.

**R308.6.1 Definitions.**

**SKYLIGHTS AND SLOPED GLAZING.** Glass or other transparent or translucent glazing material installed at a slope of 15 degrees (0.26 rad) or more from vertical. Glazing materials in skylights, including unit skylights, tubular daylighting devices, solariums, sunrooms, roofs and sloped walls are included in this definition.

**SKYLIGHT, UNIT.** A factory assembled, glazed fenestration unit, containing one panel of glazing material, that allows for natural daylighting through an opening in the roof assembly while preserving the weather-resistant barrier of the roof.

**TUBULAR DAYLIGHTING DEVICE (TDD).** A non-operable fenestration unit primarily designed to transmit daylight from a roof surface to an interior ceiling via a tubular conduit. The basic unit consists of an exterior glazed weathering surface, a light-transmitting tube with a reflective interior surface, and an interior-sealing device such as a translucent ceiling panel. The unit may be factory assembled, or field-assembled from a manufactured kit.

**R308.6.2 Permitted materials.** The following types of glazing may be used:

1. Laminated glass with a minimum 0.015-inch (0.38 mm) polyvinyl butyral interlayer for glass panes 16 square feet (1.5 m<sup>2</sup>) or less in area located such that the highest point of the glass is not more than 12 feet (3658 mm) above a walking surface or other accessible area; for higher or larger sizes, the minimum interlayer thickness shall be 0.030 inch (0.76 mm).
2. Fully tempered glass.
3. Heat-strengthened glass.
4. Wired glass.
5. *Approved* rigid plastics.

**R308.6.3 Screens, general.** For fully tempered or heat-strengthened glass, a retaining screen meeting the requirements of Section R308.6.7 shall be installed below the glass, except for fully tempered glass that meets either condition listed in Section R308.6.5.

**R308.6.4 Screens with multiple glazing.** When the inboard pane is fully tempered, heat-strengthened or wired glass, a retaining screen meeting the requirements of Section R308.6.7 shall be installed below the glass, except for either condition listed in Section R308.6.5. All other panes in the multiple glazing may be of any type listed in Section R308.6.2.

**R308.6.5 Screens not required.** Screens shall not be required when fully tempered glass is used as single glazing or the inboard pane in multiple glazing and either of the following conditions are met:

1. Glass area 16 square feet (1.49 m<sup>2</sup>) or less. Highest point of glass not more than 12 feet (3658 mm) above a walking surface or other accessible area, nominal glass thickness not more than 3/16 inch (4.8 mm), and (for multiple glazing only) the other pane or panes fully tempered, laminated or wired glass.
2. Glass area greater than 16 square feet (1.49 m<sup>2</sup>). Glass sloped 30 degrees (0.52 rad) or less from vertical, and highest point of glass not more than 10 feet (3048 mm) above a walking surface or other accessible area.

**R308.6.6 Glass in greenhouses.** Any glazing material is permitted to be installed without screening in the sloped areas of greenhouses, provided the greenhouse height at the ridge does not exceed 20 feet (6096 mm) above *grade*.

**R308.6.7 Screen characteristics.** The screen and its fastenings shall be capable of supporting twice the weight of the glazing, be firmly and substantially fastened to the framing members, and have a mesh opening of no more than 1 inch by 1 inch (25 mm by 25 mm).

**R308.6.8 Curbs for skylights.** All unit skylights installed in a roof with a pitch flatter than three units vertical in 12 units horizontal (25-percent slope) shall be mounted on a curb extending at least 4 inches (102 mm) above the plane of the roof unless otherwise specified in the manufacturer's installation instructions.

**R308.6.9 Testing and labeling of skylights.** Exterior unit skylights and tubular daylighting devices shall be tested by



an approved independent testing laboratory, and shall be labeled to indicate compliance with the requirements of one of the following specification:

AAMA/WDMA/CSA 101/I.S.2/A440, or TAS 202 (HVHZ shall comply with TAS 202).

Exterior skylights shall be labeled with a permanent label, marking, or etching providing traceability to the manufacturer and product. The following shall also be required either on a permanent label or on a temporary supplemental label applied by the manufacturer: information identifying the manufacturer, the product model/series number, positive and negative design pressure rating, product maximum size, type and thickness of glass or glazing material, impact-resistance rating if applicable, Florida Product Approval number or Miami-Dade Product Approval number, applicable test standard(s), and approved product certification agency, testing laboratory, evaluation entity or Miami-Dade Product Approval.

Labels are limited to one design pressure rating per reference standard. The temporary supplemental label shall remain on the skylight until final approval by the building official.

### SECTION R309 GARAGES AND CARPORTS

**R309.1 Floor surface.** Garage floor surfaces shall be of *approved* noncombustible material.

The area of floor used for parking of automobiles or other vehicles shall be sloped to facilitate the movement of liquids to a drain or toward the main vehicle entry doorway.

**R309.2 Carports.** Carports shall be open on at least two sides. Carport floor surfaces shall be of *approved* noncombustible material. Carports not open on at least two sides shall be considered a garage and shall comply with the provisions of this section for garages.

**Exception:** Asphalt surfaces shall be permitted at ground level in carports.

The area of floor used for parking of automobiles or other vehicles shall be sloped to facilitate the movement of liquids to a drain or toward the main vehicle entry doorway.

**R309.3 Flood hazard areas.** For buildings located in flood hazard areas as established by Table R301.2(1), garage floors shall be:

1. Elevated to or above the design flood elevation as determined in Section R322; or
2. Located below the design flood elevation provided they are at or above *grade* on at least one side, are used solely for parking, building access or storage, meet the requirements of Section R322 and are otherwise constructed in accordance with this code.

**R309.4 Automatic garage door openers.** Automatic garage door openers, if provided, shall be listed in accordance with UL 325.

### SECTION R310 EMERGENCY ESCAPE AND RESCUE OPENINGS

**R310.1 Emergency escape and rescue required.** *Basements*, habitable attics and every sleeping room shall have at least one operable emergency escape and rescue opening. Where *basements* contain one or more sleeping rooms, emergency egress and rescue openings shall be required in each sleeping room. Where emergency escape and rescue openings are provided they shall have a sill height of not more than 44 inches (1118 mm) above the floor. Where a door opening having a threshold below the adjacent ground elevation serves as an emergency escape and rescue opening and is provided with a bulkhead enclosure, the bulkhead enclosure shall comply with Section R310.3. The net clear opening dimensions required by this section shall be obtained by the normal operation of the emergency escape and rescue opening from the inside. Emergency escape and rescue openings with a finished sill height below the adjacent ground elevation shall be provided with a window well in accordance with Section R310.2. Emergency escape and rescue openings shall open directly into a public way, or to a *yard* or court that opens to a public way.

#### Exceptions:

1. *Basements* used only to house mechanical *equipment* and not exceeding total floor area of 200 square feet (18.58 m<sup>2</sup>).
2. The emergency escape and rescue opening shall be permitted to open into a screen enclosure, open to the atmosphere, where a screen door is provided leading away from the residence.

**R310.1.1 Minimum opening area.** All emergency escape and rescue openings shall have a minimum net clear opening of 5.7 square feet (0.530 m<sup>2</sup>).

**Exception:** *Grade* floor openings shall have a minimum net clear opening of 5 square feet (0.465 m<sup>2</sup>).

**R310.1.2 Minimum opening height.** The minimum net clear opening height shall be 24 inches (610 mm).

**R310.1.3 Minimum opening width.** The minimum net clear opening width shall be 20 inches (508 mm).

**R310.1.4 Operational constraints.** Emergency escape and rescue openings shall be operational from the inside of the room without the use of keys, tools or special knowledge.

**R310.2 Window wells.** The minimum horizontal area of the window well shall be 9 square feet (0.9 m<sup>2</sup>), with a minimum horizontal projection and width of 36 inches (914 mm). The area of the window well shall allow the emergency escape and rescue opening to be fully opened.

**Exception:** The ladder or steps required by Section R310.2.1 shall be permitted to encroach a maximum of 6 inches (152 mm) into the required dimensions of the window well.

**R310.2.1 Ladder and steps.** Window wells with a vertical depth greater than 44 inches (1118 mm) shall be equipped with a permanently affixed ladder or steps usable with the window in the fully open position. Ladders or steps required by this section shall not be required to comply with Sections R311.7 and R311.8. Ladders or rungs shall have an inside width of at least 12 inches (305 mm), shall project at least 3

inches (76 mm) from the wall and shall be spaced not more than 18 inches (457 mm) on center vertically for the full height of the window well.

**R310.3 Bulkhead enclosures.** Bulkhead enclosures shall provide direct access to the *basement*. The bulkhead enclosure with the door panels in the fully open position shall provide the minimum net clear opening required by Section R310.1.1. Bulkhead enclosures shall also comply with Section R311.7.8.2.

**R310.4 Bars, grilles, covers and screens.** Bars, grilles, covers, screens or similar devices are permitted to be placed over emergency escape and rescue openings, bulkhead enclosures, or window wells that serve such openings, provided the minimum net clear opening size complies with Sections R310.1.1 to R310.1.3, and such devices shall be releasable or removable from the inside without the use of a key, tool, special knowledge or force greater than that which is required for normal operation of the escape and rescue opening. The temporary installation or closure of storm shutters, panels, and other approved hurricane protection devices shall be permitted on emergency escape and rescue openings during the threat of a storm. Such devices shall not be required to comply with the operational constraints of Section R310.1.4. While such protection is provided, at least one means of escape from the dwelling or dwelling unit shall be provided. The means of escape shall be within the first floor of the dwelling or dwelling unit and shall not be located within a garage without a side-hinged door leading directly to the exterior. Occupants in any part of the dwelling or dwelling unit shall be able to access the means of escape without passing through a lockable door not under their control.

**R310.5 Emergency escape windows under decks and porches.** Emergency escape windows are allowed to be installed under decks and porches provided the location of the deck allows the emergency escape window to be fully opened and provides a path not less than 36 inches (914 mm) in height to a *yard* or court.

## SECTION R311 MEANS OF EGRESS

**R311.1 Means of egress.** All *dwelling*s shall be provided with a means of egress as provided in this section. The means of egress shall provide a continuous and unobstructed path of vertical and horizontal egress travel from all portions of the *dwelling* to the exterior of the *dwelling* at the required egress door without requiring travel through a garage.

**R311.2 Egress door.** At least one egress door shall be provided for each *dwelling* unit. The egress door shall be side-hinged, and shall provide a minimum clear width of 32 inches (813 mm) when measured between the face of the door and the stop, with the door open 90 degrees (1.57 rad). The minimum clear height of the door opening shall not be less than 78 inches (1981 mm) in height measured from the top of the threshold to the bottom of the stop. Other doors shall not be required to comply with these minimum dimensions. Egress doors shall be readily openable from inside the *dwelling* without the use of a key or special knowledge or effort.

**Exception:** Buildings that are 400 square feet or less and that are intended for use in conjunction with one- and

two-family residences are not subject to the door height and width requirements of this code.

**R311.3 Landings at doors.** There shall be a floor or landing on each side of each exterior door.

**Exception:** Where a stairway of two or fewer risers is located on the exterior side of a door, a landing is not required for the exterior side of the door.

The floor or landing at exterior doors required by Section R311.2 shall not be required to comply with this requirement but shall have a rise no greater than that permitted in Section R311.7.4.

The width of each landing shall not be less than the door served. Every landing shall have a minimum dimension of 36 inches (914 mm) measured in the direction of travel.

**R311.3.1 Floor elevations at the required egress doors.** Landings or floors at the required egress door shall not be more than 1½ inches (38 mm) lower than the top of the threshold.

**Exception:** The exterior landing or floor shall not be more than 7¾ inches (196 mm) below the top of the threshold provided the door does not swing over the landing or floor.

When exterior landings or floors serving the required egress door are not at *grade*, they shall be provided with access to *grade* by means of a ramp in accordance with Section R311.8 or a stairway in accordance with Section R311.7.

**R311.3.2 Floor elevations for other exterior doors.** Doors other than the required egress door shall be provided with landings or floors not more than 7¾ inches (196 mm) below the top of the threshold.

**Exception:** A landing is not required where a stairway of two or fewer risers is located on the exterior side of the door, provided the door does not swing over the stairway.

**R311.3.3 Storm and screen doors.** Storm and screen doors shall be permitted to swing over all exterior stairs and landings.

**R311.4 Vertical egress.** Egress from habitable levels including habitable attics and *basements* not provided with an egress door in accordance with Section R311.2 shall be by a ramp in accordance with Section R311.8 or a stairway in accordance with Section R311.7.

**R311.5 Construction.**

**R311.5.1 Attachment.** Exterior landings, decks, balconies, stairs and similar facilities shall be positively anchored to the primary structure to resist both vertical and lateral forces or shall be designed to be self-supporting. Attachment shall not be accomplished by use of toenails or nails subject to withdrawal.

**R311.6 Hallways.** The minimum width of a hallway shall be not less than 3 feet (914 mm).

**R311.7 Stairways.**

**R311.7.1 Width.** Stairways shall not be less than 36 inches (914 mm) in clear width at all points above the permitted

handrail height and below the required headroom height. Handrails shall not project more than 4.5 inches (114 mm) on either side of the stairway and the minimum clear width of the stairway at and below the handrail height, including treads and landings, shall not be less than 31½ inches (787 mm) where a handrail is installed on one side and 27 inches (698 mm) where handrails are provided on both sides.

**Exception:** The width of spiral stairways shall be in accordance with Section R311.7.9.1.

**R311.7.2 Headroom.** The minimum headroom in all parts of the stairway shall not be less than 6 feet 8 inches (2032 mm) measured vertically from the sloped line adjoining the tread nosing or from the floor surface of the landing or platform on that portion of the stairway.

**Exception:** Where the nosings of treads at the side of a flight extend under the edge of a floor opening through which the stair passes, the floor opening shall be allowed to project horizontally into the required headroom a maximum of 4¾ inches (121 mm).

**R311.7.3 Walkline.** The walkline across winder treads shall be concentric to the curved direction of travel through the turn and located 12 inches (305 mm) from the side where the winders are narrower. The 12-inch (305 mm) dimension shall be measured from the widest point of the clear stair width at the walking surface of the winder. If winders are adjacent within the flight, the point of the widest clear stair width of the adjacent winders shall be used.

**R311.7.4 Stair treads and risers.** Stair treads and risers shall meet the requirements of this section. For the purposes of this section all dimensions and dimensioned surfaces shall be exclusive of carpets, rugs or runners.

**R311.7.4.1 Riser height.** The maximum riser height shall be 7¾ inches (196 mm). The riser shall be measured vertically between leading edges of the adjacent treads. The greatest riser height within any flight of stairs shall not exceed the smallest by more than ¾ inch (9.5 mm).

**R311.7.4.2 Tread depth.** The minimum tread depth shall be 10 inches (254 mm). The tread depth shall be measured horizontally between the vertical planes of the foremost projection of adjacent treads and at a right angle to the tread's leading edge. The greatest tread depth within any flight of stairs shall not exceed the smallest by more than ¾ inch (9.5 mm). Consistently shaped winders at the walkline shall be allowed within the same flight of stairs as rectangular treads and do not have to be within ¾ inch (9.5 mm) of the rectangular tread depth.

Winder treads shall have a minimum tread depth of 10 inches (254 mm) measured between the vertical planes of the foremost projection of adjacent treads at the intersections with the walkline. Winder treads shall have a minimum tread depth of 6 inches (152 mm) at any point within the clear width of the stair. Within any flight of stairs, the largest winder tread depth at the walkline shall not exceed the smallest winder tread by more than ¾ inch (9.5 mm).

**R311.7.4.3 Profile.** The radius of curvature at the leading edge of the tread shall be no greater than 9/16 inch (14.3 mm). A nosing not less than ¾ inch (19 mm) but not more than 1¼ inches (32 mm) shall be provided on stairways with solid risers. The greatest nosing projection shall not exceed the smallest nosing projection by more than ¾ inch (9.5 mm) between two stories, including the nosing at the level of floors and landings. Beveling of nosings shall not exceed ½ inch (12.7 mm). Risers shall be vertical or sloped from the underside of the leading edge of the tread at an angle not more than 30 degrees (0.51 rad) from the vertical. Open risers are permitted, provided that the opening between treads does not permit the passage of a 4-inch (102 mm) diameter sphere.

**Exceptions:**

1. A nosing is not required where the tread depth is a minimum of 11 inches (279 mm).
2. The opening between adjacent treads is not limited on stairs with a total rise of 30 inches (762 mm) or less.

**R311.7.4.4 Exterior wood/plastic composite stair treads.** Wood/plastic composite stair treads shall comply with the provisions of Section R317.4.

**R311.7.5 Landings for stairways.** There shall be a floor or landing at the top and bottom of each stairway.

**Exception:** A floor or landing is not required at the top of an interior flight of stairs, including stairs in an enclosed garage, provided a door does not swing over the stairs. A flight of stairs shall not have a vertical rise larger than 12 feet (3658 mm) between floor levels or landings. The width of each landing shall not be less than the width of the stairway served. Every landing shall have a minimum dimension of 36 inches (914 mm) measured in the direction of travel.

**R311.7.6 Stairway walking surface.** The walking surface of treads and landings of stairways shall be sloped no steeper than one unit vertical in 48 inches horizontal (2-percent slope).

**R311.7.7 Handrails.** Handrails shall be provided on at least one side of each continuous run of treads or flight with four or more risers.

**R311.7.7.1 Height.** Handrail height, measured vertically from the sloped plane adjoining the tread nosing, or finish surface of ramp slope, shall be not less than 34 inches (864 mm) and not more than 38 inches (965 mm).

**Exceptions:**

1. The use of a volute, turnout or starting easing shall be allowed over the lowest tread.
2. When handrail fittings or bendings are used to provide continuous transition between flights, the transition from handrail to guardrail, or used at the start of a flight, the handrail height at

the fittings or bendings shall be permitted to exceed the maximum height.

**R311.7.7.2 Continuity.** Handrails for stairways shall be continuous for the full length of the flight, from a point directly above the top riser of the flight to a point directly above the lowest riser of the flight. Handrail ends shall be returned or shall terminate in newel posts or safety terminals. Handrails adjacent to a wall shall have a space of not less than 1½ inch (38 mm) between the wall and the handrails.

**Exceptions:**

1. Handrails shall be permitted to be interrupted by a newel post at the turn.
2. The use of a volute, turnout, starting easing or starting newel shall be allowed over the lowest tread.

**R311.7.7.3 Grip-size.** All required handrails shall be of one of the following types or provide equivalent graspability.

1. Type I. Handrails with a circular cross section shall have an outside diameter of at least 1¼ inches (32 mm) and not greater than 2 inches (51 mm). If the handrail is not circular, it shall have a perimeter dimension of at least 4 inches (102 mm) and not greater than 6¼ inches (160 mm) with a maximum cross section of dimension of 2¼ inches (57 mm). Edges shall have a minimum radius of 0.01 inch (0.25 mm).
2. Type II. Handrails with a perimeter greater than 6¼ inches (160 mm) shall have a graspable finger recess area on both sides of the profile. The finger recess shall begin within a distance of ¾ inch (19 mm) measured vertically from the tallest portion of the profile and achieve a depth of at least 5/16 inch (8 mm) within 7/8 inch (22 mm) below the widest portion of the profile. This required depth shall continue for at least 3/8 inch (10 mm) to a level that is not less than 1¾ inches (45 mm) below the tallest portion of the profile. The minimum width of the handrail above the recess shall be 1¼ inches (32 mm) to a maximum of 2¾ inches (70 mm). Edges shall have a minimum radius of 0.01 inch (0.25 mm).

**R311.7.7.4 Exterior wood/plastic composite handrails.** Wood/plastic composite handrails shall comply with the provisions of Section R317.4.

**R311.7.8 Illumination.** All stairs shall be provided with illumination in accordance with Section R303.6.

**R311.7.9 Special stairways.** Spiral stairways and bulkhead enclosure stairways shall comply with all requirements of Section R311.7 except as specified below.

**R311.7.9.1 Spiral stairways.** Spiral stairways are permitted, provided the minimum clear width at and below the handrail shall be 26 inches (660 mm) with each tread

having a 7½-inch (190 mm) minimum tread depth at 12 inches (914 mm) from the narrower edge. All treads shall be identical, and the rise shall be no more than 9½ inches (241 mm). A minimum headroom of 6 feet 6 inches (1982 mm) shall be provided.

**R311.7.9.2 Bulkhead enclosure stairways.** Stairways serving bulkhead enclosures, not part of the required building egress, providing access from the outside *grade* level to the *basement* shall be exempt from the requirements of Sections R311.3 and R311.7 where the maximum height from the *basement* finished floor level to *grade* adjacent to the stairway does not exceed 8 feet (2438 mm) and the *grade* level opening to the stairway is covered by a bulkhead enclosure with hinged doors or other *approved* means.

**R311.7.9.3 Circular stairways.** Circular stairs may have a minimum tread depth of 9 inches (229 mm) with 1 inch (25.4 mm) of nosing, and the smaller radius may be less than twice the width of the stairway.

**R311.8 Ramps.**

**R311.8.1 Maximum slope.** Ramps shall have a maximum slope of 1 unit vertical in 12 units horizontal (8.3 percent slope).

**Exception:** Where it is technically infeasible to comply because of site constraints, ramps may have a maximum slope of one unit vertical in eight horizontal (12.5 percent slope).

**R311.8.2 Landings required.** A minimum 3-foot-by-3-foot (914 mm by 914 mm) landing shall be provided:

1. At the top and bottom of ramps.
2. Where doors open onto ramps.
3. Where ramps change direction.

**R311.8.3 Handrails required.** Handrails shall be provided on at least one side of all ramps exceeding a slope of one unit vertical in 12 units horizontal (8.33-percent slope).

**R311.8.3.1 Height.** Handrail height, measured above the finished surface of the ramp slope, shall be not less than 34 inches (864 mm) and not more than 38 inches (965 mm).

**R311.8.3.2 Grip size.** Handrails on ramps shall comply with Section R311.7.7.3.

**R311.8.3.3 Continuity.** Handrails where required on ramps shall be continuous for the full length of the ramp. Handrail ends shall be returned or shall terminate in newel posts or safety terminals. Handrails adjacent to a wall shall have a space of not less than 1½ inches (38 mm) between the wall and the handrails.

**SECTION R312  
GUARDS**

**R312.1 Where required.** *Guards* shall be located along open-sided walking surfaces, including stairs, ramps and landings, that are located more than 30 inches (762 mm) measured vertically to the floor or *grade* below at any point within 36

inches (914 mm) horizontally to the edge of the open side. Insect screening shall not be considered as a *guard*.

**R312.2 Height.** Required *guards* at open-sided walking surfaces, including stairs, porches, balconies or landings, shall be not less than 36 inches (914 mm) high measured vertically above the adjacent walking surface, adjacent fixed seating or the line connecting the leading edges of the treads.

**Exceptions:**

1. *Guards* on the open sides of stairs shall have a height not less than 34 inches (864 mm) measured vertically from a line connecting the leading edges of the treads.
2. Where the top of the *guard* also serves as a handrail on the open sides of stairs, the top of the *guard* shall not be not less than 34 inches (864 mm) and not more than 38 inches (965 mm) measured vertically from a line connecting the leading edges of the treads.

**R312.3 Opening limitations.** Required *guards* shall not have openings from the walking surface to the required *guard* height which allow passage of a sphere 4 inches (102 mm) in diameter.

**Exceptions:**

1. The triangular openings at the open side of a stair, formed by the riser, tread and bottom rail of a *guard*, shall not allow passage of a sphere 6 inches (153 mm) in diameter.
2. *Guards* on the open sides of stairs shall not have openings which allow passage of a sphere  $4\frac{3}{8}$  inches (111 mm) in diameter.

**R312.4 Exterior woodplastic composite guards.** Woodplastic composite *guards* shall comply with the provisions of Section R317.4.

## SECTION R313 AUTOMATIC FIRE SPRINKLER SYSTEMS RESERVED

## SECTION R314 SMOKE ALARMS

**R314.1 Smoke detection and notification.** All smoke alarms shall be listed in accordance with UL 217 and installed in accordance with the provisions of this code and the household fire warning *equipment* provisions of NFPA 72.

**R314.2 Smoke detection systems.** Household fire alarm systems installed in accordance with NFPA 72 that include smoke alarms, or a combination of smoke detector and audible notification device installed as required by this section for smoke alarms, shall be permitted. The household fire alarm system shall provide the same level of smoke detection and alarm as required by this section for smoke alarms. Where a household fire warning system is installed using a combination of smoke detector and audible notification device(s), it shall become a permanent fixture of the occupancy and owned by the homeowner. The system shall be monitored by an *approved* supervising station and be maintained in accordance with NFPA 72.

**Exception:** Where smoke alarms are provided meeting the requirements of Section R314.4.

**R314.3 Location.** Smoke alarms shall be installed in the following locations:

1. In each sleeping room.
2. Outside each separate sleeping area in the immediate vicinity of the bedrooms.
3. On each additional *story* of the *dwelling*, including *basements* and habitable attics but not including crawl spaces and uninhabitable *attics*. In *dwelling*s or *dwelling units* with split levels and without an intervening door between the adjacent levels, a smoke alarm installed on the upper level shall suffice for the adjacent lower level provided that the lower level is less than one full *story* below the upper level.

When more than one smoke alarm is required to be installed within an individual *dwelling* unit the alarm devices shall be interconnected in such a manner that the actuation of one alarm will activate all of the alarms in the individual unit.

**R314.3.1 Alterations, repairs and additions.** When *alterations*, repairs or *additions* requiring a *permit* occur, or when one or more sleeping rooms are added or created in existing *dwelling*s, the individual *dwelling unit* shall be equipped with smoke alarms located as required for new *dwelling*s.

**Exceptions:**

1. Work involving the exterior surfaces of *dwelling*s, such as the replacement of roofing or siding, or the *addition* or replacement of windows or doors, or the *addition* of a porch or deck, are exempt from the requirements of this section.
2. Installation, *alteration* or repairs of plumbing or mechanical systems are exempt from the requirements of this section.

**R314.4 Power source.** Smoke alarms shall receive their primary power from the building wiring when such wiring is served from a commercial source, and when primary power is interrupted, shall receive power from a battery. Wiring shall be permanent and without a disconnecting switch other than those required for overcurrent protection. Smoke alarms shall be interconnected.

**Exceptions:**

1. Smoke alarms shall be permitted to be battery operated when installed in buildings without commercial power.
2. Interconnection and hard-wiring of smoke alarms in existing areas shall not be required where the *alterations* or repairs do not result in the removal of interior wall or ceiling finishes exposing the structure, unless there is an *attic*, crawl space or *basement* available which could provide access for hard wiring and interconnection without the removal of interior finishes.

## SECTION R315 CARBON MONOXIDE ALARMS

**R315.1 Carbon monoxide protection.** Every separate building or an addition to an existing building for which a permit for new construction is issued and having a fossil-fuel-burning heater or appliance, a fireplace, an attached garage, or other feature, fixture, or element that emits carbon monoxide as a byproduct of combustion shall have an operational carbon monoxide alarm installed within 10 feet of each room used for sleeping purposes.

**Exception:** This section shall not apply to existing buildings that are undergoing alterations or repair unless the alteration is an addition as defined in Section R315.1.3.

**R315.1.1 Carbon monoxide alarm.** The requirements of Section R315.1 shall be satisfied by providing for one of the following alarm installations:

- (1) A hard-wired carbon monoxide alarm.
- (2) A battery-powered carbon monoxide alarm.
- (3) A hard-wired combination carbon monoxide and smoke alarm.
- (4) A battery-powered combination carbon monoxide and smoke alarm.

**R315.1.2 Combination alarms.** Combination smoke/carbon monoxide alarms shall be listed and labeled by a Nationally Recognized Testing Laboratory.

**R315.1.3 Addition shall mean:** An extension or increase in floor area, number of stories or height of a building or structure.

**R315.2 Where required in existing dwellings.** Reserved.

**R315.3 Alarm requirements.** Reserved.

## SECTION R316 FOAM PLASTIC

**R316.1 General.** The provisions of this section shall govern the materials, design, application, construction and installation of foam plastic materials.

**R316.2 Labeling and identification.** Packages and containers of foam plastic insulation and foam plastic insulation components delivered to the job site shall bear the *label* of an *approved agency* showing the manufacturer's name, the product listing, product identification and information sufficient to determine that the end use will comply with the requirements.

**R316.3 Surface burning characteristics.** Unless otherwise allowed in Section R316.5 or R316.6, all foam plastic or foam plastic cores used as a component in manufactured assemblies used in building construction shall have a flame spread index of not more than 75 and shall have a smoke-developed index of not more than 450 when tested in the maximum thickness intended for use in accordance with ASTM E 84 or UL 723. Loose-fill type foam plastic insulation shall be tested as board stock for the flame spread index and smoke-developed index.

**Exception:** Foam plastic insulation more than 4 inches (102 mm) thick shall have a maximum flame spread index of 75

and a smoke-developed index of 450 where tested at a minimum thickness of 4 inches (102 mm), provided the end use is *approved* in accordance with Section R316.6 using the thickness and density intended for use.

**R316.4 Thermal barrier.** Unless otherwise allowed in Section R316.5 or Section R316.6, foam plastic shall be separated from the interior of a building by an *approved* thermal barrier of minimum  $\frac{1}{2}$  inch (12.7 mm) gypsum wallboard or an *approved* finish material equivalent to a thermal barrier material that will limit the average temperature rise of the unexposed surface to no more than 250°F (139°C) after 15 minutes of fire exposure complying with the ASTM E 119 or UL 263 standard time temperature curve. The thermal barrier shall be installed in such a manner that it will remain in place for 15 minutes based on NFPA 286 with the acceptance criteria of Section R302.9.4, FM 4880, UL 1040 or UL 1715.

**R316.5 Specific requirements.** The following requirements shall apply to these uses of foam plastic unless specifically *approved* in accordance with Section R316.6 or by other sections of the code or the requirements of Sections R316.2 through R316.4 have been met.

**R316.5.1 Masonry or concrete construction.** The thermal barrier specified in Section R316.4 is not required in a masonry or concrete wall, floor or roof when the foam plastic insulation is separated from the interior of the building by a minimum 1-inch (25 mm) thickness of masonry or concrete.

**R316.5.2 Roofing.** The thermal barrier specified in Section R316.4 is not required when the foam plastic in a roof assembly or under a roof covering is installed in accordance with the code and the manufacturer's installation instructions and is separated from the interior of the building by tongue-and-groove wood planks or wood structural panel sheathing in accordance with Section R803, not less than  $\frac{15}{32}$  inch (11.9 mm) thick bonded with exterior glue and identified as Exposure 1, with edges supported by blocking or tongue-and-groove joints or an equivalent material. The smoke-developed index for roof applications shall not be limited.

**R316.5.3 Attics.** The thermal barrier specified in Section R316.4 is not required where all of the following apply:

1. *Attic* access is required by Section R807.1.
2. The space is entered only for purposes of repairs or maintenance.
3. The foam plastic insulation is protected against ignition using one of the following ignition barrier materials:
  - 3.1.  $\frac{1}{2}$ -inch-thick (38 mm) mineral fiber insulation;
  - 3.2.  $\frac{1}{4}$ -inch-thick (6.4 mm) wood structural panels;
  - 3.3.  $\frac{3}{8}$ -inch (9.5 mm) particleboard;
  - 3.4.  $\frac{1}{4}$ -inch (6.4 mm) hardboard;
  - 3.5.  $\frac{3}{8}$ -inch (9.5 mm) gypsum board; or

- 3.6. Corrosion-resistant steel having a base metal thickness of 0.016 inch (0.406 mm).

The above ignition barrier is not required where the foam plastic insulation has been tested in accordance with Section R316.6.

**R316.5.4 Crawl spaces.** The thermal barrier specified in Section R316.4 is not required where all of the following apply:

1. Crawlspace access is required by Section R408.4
2. Entry is made only for purposes of repairs or maintenance.
3. The foam plastic insulation is protected against ignition using one of the following ignition barrier materials:
  - 3.1. 1½-inch-thick (38 mm) mineral fiber insulation;
  - 3.2. ¼-inch-thick (6.4 mm) wood structural panels;
  - 3.3. ⅜-inch (9.5 mm) particleboard;
  - 3.4. ¼-inch (6.4 mm) hardboard;
  - 3.5. ⅜-inch (9.5 mm) gypsum board; or
  - 3.6. Corrosion-resistant steel having a base metal thickness of 0.016 inch (0.406 mm).

The above ignition barrier is not required where the foam plastic insulation has been tested in accordance with Section R316.6.

**R316.5.5 Foam-filled exterior doors.** Foam-filled exterior doors are exempt from the requirements of Sections R316.3 and R316.4.

**R316.5.6 Foam-filled garage doors.** Foam-filled garage doors in attached or detached garages are exempt from the requirements of Sections R316.3 and R316.4.

**R316.5.7 Foam backer board.** The thermal barrier specified in Section R316.4 is not required where siding backer board foam plastic insulation has a maximum thickness of 0.5 inch (12.7 mm) and a potential heat of not more than 2000 BTU per square foot (22 720 kJ/m<sup>2</sup>) when tested in accordance with NFPA 259 provided that:

1. The foam plastic insulation is separated from the interior of the building by not less than 2 inches (51 mm) of mineral fiber insulation;
2. The foam plastic insulation is installed over existing *exterior wall* finish in conjunction with re-siding;
3. The foam plastic insulation has been tested in accordance with Section R316.6.

**R316.5.8 Re-siding.** The thermal barrier specified in Section R316.4 is not required where the foam plastic insulation is installed over existing *exterior wall* finish in conjunction with re-siding provided the foam plastic has a maximum thickness of 0.5 inch (12.7 mm) and a potential heat of not more than 2000 Btu per square foot (22 720 kJ/m<sup>2</sup>) when tested in accordance with NFPA 259.

**R316.5.9 Interior trim.** The thermal barrier specified in Section R316.4 is not required for exposed foam plastic interior trim, provided all of the following are met:

1. The minimum density is 20 pounds per cubic foot (314 kg/m<sup>3</sup>).
2. The maximum thickness of the trim is 0.5 inch (12.7 mm) and the maximum width is 8 inches (204 mm).
3. The trim constitutes no more than 10 percent of the area of any wall or ceiling.
4. The flame spread index does not exceed 75 when tested per ASTM E 84. The smoke-developed index is not limited.

**R316.5.10 Interior finish.** Foam plastics shall be permitted as interior finish where *approved* in accordance with Section R316.6 Foam plastics that are used as interior finish shall also meet the flame spread index and smoke-developed index requirements of Sections R302.9.1 and R302.9.2.

**R316.5.11 Sill plates and headers.** Foam plastic shall be permitted to be spray applied to a sill plate and header without the thermal barrier specified in Section R316.4 subject to all of the following:

1. The maximum thickness of the foam plastic shall be 3¼ inches (83 mm).
2. The density of the foam plastic shall be in the range of 0.5 to 2.0 pounds per cubic foot (8 to 32 kg/m<sup>3</sup>).
3. The foam plastic shall have a flame spread index of 25 or less and an accompanying smoke developed index of 450 or less when tested in accordance with ASTM E 84.

**R316.5.12 Sheathing.** Foam plastic insulation used as sheathing shall comply with Section R316.3 and Section R316.4. Where the foam plastic sheathing is exposed to the *attic* space at a gable or kneewall, the provisions of Section R316.5.3 shall apply.

**R316.6 Specific approval.** Foam plastic not meeting the requirements of Sections R316.3 through R316.5 shall be specifically approved on the basis of one of the following approved tests: NFPA 286 with the acceptance criteria of Section R302.9.4, FM 4880, UL 723, UL 1040 or UL 1715, or fire tests related to actual end-use configurations. The specific approval shall be based on the actual end use configuration and shall be performed on the finished foam plastic assembly in the maximum thickness intended for use. Assemblies tested shall include seams, joints and other typical details used in the installation of the assembly and shall be tested in the manner intended for use.

**R316.7 Termite damage.** The use of foam plastics in areas of “very heavy” termite infestation probability shall be in accordance with Section R318.5.

## SECTION R317 PROTECTION OF WOOD AND WOOD BASED PRODUCTS AGAINST DECAY

**R317.1 Location required.** Protection of wood and wood based products from decay shall be provided in the following locations by the use of naturally durable wood or wood that is preservative-treated in accordance with AWPA U1 for the species, product, preservative and end use. Preservatives shall be listed in Section 4 of AWPA U1.

1. Wood joists or the bottom of a wood structural floor when closer than 18 inches (457 mm) or wood girders when closer than 12 inches (305 mm) to the exposed ground in crawl spaces or unexcavated area located within the periphery of the building foundation.
2. All wood framing members that rest on concrete or masonry exterior foundation walls and are less than 8 inches (203 mm) from the exposed ground.
3. Sills and sleepers on a concrete or masonry slab that is in direct contact with the ground unless separated from such slab by an impervious moisture barrier.
4. The ends of wood girders entering exterior masonry or concrete walls having clearances of less than  $\frac{1}{2}$  inch (12.7 mm) on tops, sides and ends.
5. Wood siding, sheathing and wall framing on the exterior of a building having a clearance of less than 6 inches (152 mm) from the ground or less than 2 inches (51 mm) measured vertically from concrete steps, porch slabs, patio slabs, and similar horizontal surfaces exposed to the weather.
6. Wood structural members supporting moisture-permeable floors or roofs that are exposed to the weather, such as concrete or masonry slabs, unless separated from such floors or roofs by an impervious moisture barrier.
7. Wood furring strips or other wood framing members attached directly to the interior of exterior masonry walls or concrete walls below *grade* except where an *approved* vapor retarder is applied between the wall and the furring strips or framing members.

**R317.1.1 Field treatment.** Field-cut ends, notches and drilled holes of preservative-treated wood shall be treated in the field in accordance with AWPA M4.

**R317.1.2 Ground contact.** All wood in contact with the ground, embedded in concrete in direct contact with the ground or embedded in concrete exposed to the weather that supports permanent structures intended for human occupancy shall be *approved* pressure-preservative-treated wood suitable for ground contact use, except untreated wood may be used where entirely below groundwater level or continuously submerged in fresh water.

**R317.1.3 Geographical areas.** In geographical areas where experience has demonstrated a specific need, *approved* naturally durable or pressure-preservative-treated wood shall be used for those portions of wood members that form the structural supports of buildings, balconies, porches or similar permanent building appurtenances when those members are exposed to the weather without adequate protection

from a roof, eave, overhang or other covering that would prevent moisture or water accumulation on the surface or at joints between members. Depending on local experience, such members may include:

1. Horizontal members such as girders, joists and decking.
2. Vertical members such as posts, poles and columns.
3. Both horizontal and vertical members.

**R317.1.4 Wood columns.** Wood columns shall be *approved* wood of natural decay resistance or *approved* pressure-preservative-treated wood.

### Exceptions:

1. Columns exposed to the weather or in *basements* when supported by concrete piers or metal pedestals projecting 1 inch (25.4 mm) above a concrete floor or 6 inches (152 mm) above exposed earth and the earth is covered by an *approved* impervious moisture barrier.
2. Columns in enclosed crawl spaces or unexcavated areas located within the periphery of the building when supported by a concrete pier or metal pedestal at a height more than 8 inches (203mm) from exposed earth and the earth is covered by an impervious moisture barrier.

**R317.1.5 Exposed glued-laminated timbers.** The portions of glued-laminated timbers that form the structural supports of a building or other structure and are exposed to weather and not properly protected by a roof, eave or similar covering shall be pressure treated with preservative, or be manufactured from naturally durable or preservative-treated wood.

**R317.2 Quality mark.** Lumber and plywood required to be pressure-preservative-treated in accordance with Section R317.1 shall bear the quality *mark* of an *approved* inspection agency that maintains continuing supervision, testing and inspection over the quality of the product and that has been *approved* by an accreditation body that complies with the requirements of the American Lumber Standard Committee treated wood program.

**R317.2.1 Required information.** The required quality *mark* on each piece of pressure-preservative-treated lumber or plywood shall contain the following information:

1. Identification of the treating plant.
2. Type of preservative.
3. The minimum preservative retention.
4. End use for which the product was treated.
5. Standard to which the product was treated.
6. Identity of the *approved* inspection agency.
7. The designation "Dry," if applicable.

**Exception:** Quality *marks* on lumber less than 1 inch (25.4 mm) nominal thickness, or lumber less than nominal 1 inch by 5 inches (25.4 mm by 127 mm) or 2 inches by 4 inches (51 mm by 102 mm) or lumber 36 inches (914 mm) or less in length shall be applied by stamping the faces of exterior



pieces or by end labeling not less than 25 percent of the pieces of a bundled unit.

**R317.3 Fasteners and connectors in contact with preservative-treated and fire-retardant-treated wood.** Fasteners and connectors in contact with preservative-treated wood and fire-retardant-treated wood shall be in accordance with this section. The coating weights for zinc-coated fasteners shall be in accordance with ASTM A 153.

**R317.3.1 Fasteners for preservative-treated wood.** Fasteners for preservative-treated wood shall be of hot dipped zinc-coated galvanized steel, stainless steel, silicon bronze or copper. Coating types and weights for connectors in contact with preservative-treated wood shall be in accordance with the connector manufacturer's recommendations. In the absence of manufacturer's recommendations, a minimum of ASTM A 653 type G185 zinc-coated galvanized steel, or equivalent, shall be used.

**Exceptions:**

1. One-half-inch (12.7 mm) diameter or greater steel bolts.
2. Fasteners other than nails and timber rivets shall be permitted to be of mechanically deposited zinc coated steel with coating weights in accordance with ASTM B 695, Class 55 minimum.

**R317.3.2 Fastenings for wood foundations.** Fastenings for wood foundations shall be as required in AF&PA PWF.

**R317.3.3 Fasteners for fire-retardant-treated wood used in exterior applications or wet or damp locations.** Fasteners for fire-retardant-treated wood used in exterior applications or wet or damp locations shall be of hot-dipped zinc-coated galvanized steel, stainless steel, silicon bronze or copper. Fasteners other than nails and timber rivets shall be permitted to be of mechanically deposited zinc-coated steel with coating weights in accordance with ASTM B 695, Class 55 minimum.

**R317.3.4 Fasteners for fire-retardant-treated wood used in interior applications.** Fasteners for fire-retardant-treated wood used in interior locations shall be in accordance with the manufacturer's recommendations. In the absence of the manufacturer's recommendations, Section R317.3.3 shall apply.

**R317.4 Wood/plastic composites.** Wood/plastic composites used in exterior deck boards, stair treads, handrails and guard-rail systems shall bear a *label* indicating the required performance levels and demonstrating compliance with the provisions of ASTM D 7032.

**R317.4.1** Wood/plastic composites shall be installed in accordance with the manufacturer's instructions.

## SECTION R318 PROTECTION AGAINST TERMITES

**R318.1 Termite Protection.** Termite protection shall be provided by registered termiticides, including soil applied pesticides, baiting systems, and pesticides applied to wood, or other approved methods of termite protection labeled for use as a preventative treatment to new construction. See Section 202, REGISTERED TERMITICIDE. Upon completion of the application of the termite protective treatment, a Certificate of Compliance shall be issued to the building department by the licensed pest control company that contains the following statement: "The building has received a complete treatment for the prevention of subterranean termites. Treatment is in accordance with rules and laws established by the Florida Department of Agriculture and Consumer Services."

**R318.1.1** If soil treatment used for subterranean termite prevention, the initial chemical soil treatment inside the foundation perimeter shall be done after all excavation, backfilling and compaction is complete.

**R318.1.2** If soil treatment is used for subterranean termite prevention, soil area disturbed after initial chemical soil treatment shall be retreated with a chemical soil treatment, including spaces boxed or formed.

**R318.1.3** If soil treatment is used for subterranean termite prevention, space in concrete floors boxed out or formed for the subsequent installation of plumbing traps, drains or any other purpose shall be created by using plastic or metal permanently placed forms of sufficient depth to eliminate any planned soil disturbance after initial chemical soil treatment.

**R318.1.4** If soil treatment is used for subterranean termite prevention, chemically treated soil shall be protected with a minimum 6 mil vapor retarder to protect against rainfall dilution. If rainfall occurs before vapor retarder placement, retreatment is required. Any work, including placement of reinforcing steel, done after chemical treatment until the concrete floor is poured, shall be done in such manner as to avoid penetrating or disturbing treated soil.

**R318.1.5** If soil treatment is used for subterranean termite prevention, concrete overpour or mortar accumulated along the exterior foundation perimeter shall be removed prior to exterior chemical soil treatment, to enhance vertical penetration of the chemicals.

**R318.1.6** If soil treatment is used for subterranean termite prevention, chemical soil treatments shall also be applied under all exterior concrete or grade within 1 foot (305 mm) of the primary structure sidewalls. Also, a vertical chemical barrier shall be applied promptly after construction is completed, including initial landscaping and irrigation/sprinkler installation. Any soil disturbed after the chemical vertical barrier is applied shall be promptly retreated.

**R318.1.7** If a registered termiticide formulated and registered as a bait system is used for subterranean termite prevention, Section R318.1.1 through Section R318.1.6 do not

apply; however, a signed contract assuring the installation, maintenance and monitoring of the baiting system for a minimum of five years from the issue of the Certificate of Occupancy shall be provided to the building official prior to the pouring of the slab, and the system must be installed prior to final building approval.

If the baiting system directions for use require a monitoring phase prior to installation of the pesticide active ingredient, the installation of the monitoring phase components shall be deemed to constitute installation of the system.

**R318.1.8** If a registered termiticide formulated and registered as a wood treatment is used for subterranean termite prevention, Sections R318.1.1 through R318.1.6 do not apply. Application of the wood treatment termiticide shall be as required by label directions for use, and must be completed prior to final building approval.

**R318.2 Penetration.** Protective sleeves around piping penetrating concrete slab-on-grade floors shall not be of cellulose-containing materials. If soil treatment is used for subterranean termite protection, the sleeve shall have a maximum wall thickness of 0.010 inch (0.25 mm), and be sealed within the slab using a non-corrosive clamping device to eliminate the annular space between the pipe and the sleeve. No termiticides shall be applied inside the sleeve.

**R318.3 Cleaning.** Cells and cavities in masonry units and air gaps between brick, stone or masonry veneers and the structure shall be cleaned of all non-preserved treated or non-naturally durable wood, or other cellulose-containing material prior to concrete placement.

**Exception:** Inorganic material manufactured for closing cells in foundation concrete masonry unit construction or clean earth fill placed in concrete masonry unit voids below slab level before termite treatment is performed.

**R318.4 Concrete bearing ledge.** Brick, stone or other veneer shall be supported by a concrete bearing ledge at least equal to the total thickness of the brick, stone or other veneer which is poured integrally with the concrete foundation. No supplemental concrete foundation pours which will create a hidden cold joint shall be used without supplemental treatment in the foundation unless there is an approved physical barrier. An approved physical barrier shall also be installed from below the wall sill plate or first block course horizontally to embed in a mortar joint. If masonry veneer extends below grade, a termite protective treatment must be applied to the cavity created between the veneer and the foundation, in lieu of a physical barrier.

**Exception:** Veneer supported by a structural member secured to the foundation sidewall in accordance with ACI 530/ASCE 5/TMS 402, provided at least a 6 inch (152 mm) clear inspection space of the foundation sidewall exterior exist between the veneer and the top of any soil, sod, mulch or other organic landscaping component, deck, apron, porch, walk or any other work immediately adjacent to or adjoining the structure.

**R318.5 Foam plastic protection.** In areas where the probability of termite infestation is “very heavy” as indicated in Figure R301.2(6), extruded and expanded polystyrene,

polyisocyanurate and other foam plastics shall not be installed on the exterior face or under interior or exterior foundation walls or slab foundations located below grade. The clearance between foam plastics installed above grade and exposed earth shall be at least 6 inches (152 mm).

**Exceptions:**

1. Buildings where the structural members of walls, floors, ceilings and roofs are entirely of noncombustible materials or pressure-preservative-treated wood.
2. When in addition to the requirements of Section R318.1, an approved method of protecting the foam plastic and structure from subterranean termite damage is used.
3. On the interior side of basement walls.

**R318.6 Protection against decay and termites.** Condensate lines, irrigation/sprinkler system risers for spray heads, and roof downspouts shall discharge at least 1 foot (305 mm) away from the structure sidewall, whether by underground piping, tail extensions or splash blocks. Gutters with downspouts are required on all buildings with eaves of less than 6 inches (152 mm) horizontal projection except for gable end rakes or on a roof above another roof.

**R318.7 Preparation of building site and removal of debris.**

**R318.7.1** All building sites shall be graded to provide drainage under all portions of the building not occupied by basements.

**R318.7.2** The foundation and the area encompassed within 1 foot (305 mm) therein shall have all vegetation, stumps, dead roots, cardboard, trash and foreign material removed and the fill material shall be free of vegetation and foreign material. The fill shall be compacted to assure adequate support of the foundation.

**R318.7.3** After all work is completed, loose wood and debris shall be completely removed from under the building and within 1 foot (305 mm) thereof. All wood forms and supports shall be completely removed. This includes, but is not limited to: wooden grade stakes, forms, contraction spacers, tub trap boxes, plumbing supports, bracing, shoring, forms or other cellulose-containing material placed in any location where such materials are not clearly visible and readily removable prior to completion of the work. Wood shall not be stored in contact with the ground under any building.

**SECTION R319  
SITE ADDRESS**

**R319.1 Address numbers.** Buildings shall have *approved* address numbers, building numbers or *approved* building identification placed in a position that is plainly legible and visible from the street or road fronting the property. These numbers shall contrast with their background. Address numbers shall be Arabic numbers or alphabetical letters. Numbers shall be a minimum of 4 inches (102 mm) high with a minimum stroke width of 1/2 inch (12.7 mm). Where access is by means of a private road and the building address cannot be viewed from the

public way, a monument, pole or other sign or means shall be used to identify the structure.

### SECTION R320 ACCESSIBILITY

**R320.1 Scope.** Shall be in accordance with the provisions of the *Florida Building Code, Accessibility*.

**R320.1.1** All new single-family houses, duplexes, triplexes, condominiums and townhouses shall provide at least one bathroom, located with maximum possible privacy, where bathrooms are provided on habitable grade levels, with a door that has a 29-inch (737 mm) clear opening. However, if only a toilet room is provided at grade level, such toilet rooms shall have a clear opening of not less than 29 inches (737 mm).

### SECTION R321 ELEVATORS AND PLATFORM LIFTS

**R321.1 Elevators.** Where provided, passenger elevators, limited-use/limited-application elevators or private residence elevators shall comply with ASME A17.1.

**R321.2 Platform lifts.** Where provided, platform lifts shall comply with ASME A18.1.

**R321.3 Accessibility.** Reserved.

### SECTION R322 FLOOD-RESISTANT CONSTRUCTION

**R322.1 General.** Buildings and structures constructed in whole or in part in flood hazard areas (including A or V Zones) as established in Table R301.2(1) shall be designed and constructed in accordance with the provisions contained in this section.

**Exception:** Buildings and structures located in whole or in part in identified floodways shall be designed and constructed in accordance with ASCE 24.

**R322.1.1 Alternative provisions.** As an alternative to the requirements in Section R322.2 for buildings and structures located in whole or in part in flood hazard areas (A Zones) or the requirements of Section 322.3 in coastal high-hazard areas (V Zones), ASCE 24 is permitted subject to the limitations of this code and the limitations therein.

**R322.1.2 Structural systems.** All structural systems of all buildings and structures shall be designed, connected and anchored to resist flotation, collapse or permanent lateral movement due to structural loads and stresses from flooding equal to the design flood elevation.

**R322.1.3 Flood-resistant construction.** All buildings and structures erected in areas prone to flooding shall be constructed by methods and practices that minimize flood damage.

**R322.1.4 Establishing the design flood elevation.** The design flood elevation shall be used to define areas prone to

flooding. At a minimum, the design flood elevation is the higher of:

1. The base flood elevation at the depth of peak elevation of flooding (including wave height) which has a 1 percent (100-year flood) or greater chance of being equaled or exceeded in any given year, or
2. The elevation of the design flood associated with the area designated on a flood hazard map adopted by the community, or otherwise legally designated.

**R322.1.4.1 Determination of design flood elevations.** If design flood elevations are not specified, the *building official* is authorized to require the applicant to:

1. Obtain and reasonably use data available from a federal, state or other source; or
2. Determine the design flood elevation in accordance with accepted hydrologic and hydraulic engineering practices used to define special flood hazard areas. Determinations shall be undertaken by a registered *design professional* who shall document that the technical methods used reflect currently accepted engineering practice. Studies, analyses and computations shall be submitted in sufficient detail to allow thorough review and approval.

**R322.1.4.2 Determination of impacts.** In riverine flood hazard areas where design flood elevations are specified but floodways have not been designated, the applicant shall demonstrate that the effect of the proposed buildings and structures on design flood elevations, including fill, when combined with all other existing and anticipated flood hazard area encroachments, will not increase the design flood elevation more than 1 foot (305 mm) at any point within the jurisdiction.

**R322.1.5 Lowest floor.** The lowest floor shall be the floor of the lowest enclosed area, including *basement*, but excluding any unfinished flood-resistant enclosure that is useable solely for vehicle parking, building access or limited storage provided that such enclosure is not built so as to render the building or structure in violation of this section.

**R322.1.6 Protection of mechanical and electrical systems.** Electrical systems, *equipment* and components; heating, ventilating, air conditioning; plumbing *appliances* and plumbing fixtures; *duct systems*; and other service *equipment* shall be located at or above the elevation required in Section R322.2 (flood hazard areas including A Zones) or R322.3 (coastal high-hazard areas including V Zones). If replaced as part of a substantial improvement, electrical systems, *equipment* and components; heating, ventilating, air conditioning and plumbing *appliances* and plumbing fixtures; *duct systems*; and other service *equipment* shall meet the requirements of this section. Systems, fixtures, and *equipment* and components shall not be mounted on or penetrate through walls intended to break away under flood loads.

**Exception:** Locating electrical systems, *equipment* and components; heating, ventilating, air conditioning; plumbing *appliances* and plumbing fixtures; *duct systems*; and other service *equipment* is permitted below the

elevation required in Section R322.2 (flood hazard areas including A Zones) or R322.3 (coastal high-hazard areas including V Zones) provided that they are designed and installed to prevent water from entering or accumulating within the components and to resist hydrostatic and hydrodynamic loads and stresses, including the effects of buoyancy, during the occurrence of flooding to the design flood elevation in accordance with ASCE 24. Electrical wiring systems are permitted to be located below the required elevation provided they conform to the provisions of the electrical part of this code for wet locations.

**R322.1.7 Protection of water supply and sanitary sewage systems.** New and replacement water supply systems shall be designed to minimize or eliminate infiltration of flood waters into the systems in accordance with the plumbing provisions of this code. New and replacement sanitary sewage systems shall be designed to minimize or eliminate infiltration of floodwaters into systems and discharges from systems into floodwaters in accordance with the plumbing provisions of this code and in accordance with Chapter 64E-6, *Florida Administrative Code*, Standards for Onsite Sewage Treatment and Disposal Systems.

**R322.1.8 Flood-resistant materials.** Building materials used below the elevation required in Section R322.2 (flood hazard areas including A Zones) or R322.3 (coastal high-hazard areas including V Zones) shall comply with the following:

1. All wood, including floor sheathing, shall be pressure-preservative-treated in accordance with AWP A U1 for the species, product, preservative and end use or be the decay-resistant heartwood of redwood, black locust or cedars. Preservatives shall be listed in Section 4 of AWP A U1.
2. Materials and installation methods used for flooring and interior and *exterior walls* and wall coverings shall conform to the provisions of FEMA/FIA-TB-2.

**R322.1.9 Manufactured homes.** In addition to the applicable requirements of the state agency with jurisdiction over installation of manufactured homes, installation of manufactured homes in flood hazard areas is subject to the applicable provisions of the local floodplain management ordinance.

**R322.1.10 As-built elevation documentation.** A registered *design professional* shall prepare and seal documentation of the elevations specified in Section R322.2 or R322.3.

**R322.1.11 Structures seaward of a coastal construction line.** In addition to the requirements of this section, structures located in flood hazard areas and seaward of the coastal construction line shall be designed to resist the predicted forces of a 100-year storm event in accordance with Section R3109 of the *Florida Building Code, Building*, and the more restrictive provisions shall govern.

**R322.2 Flood hazard areas (including A Zones).** All areas that have been determined to be prone to flooding but not subject to high velocity wave action shall be designated as flood hazard areas. Flood hazard areas that have been delineated as

subject to wave heights between 1½ feet (457 mm) and 3 feet (914 mm) shall be designated as Coastal A Zones. All building and structures constructed in whole or in part in flood hazard areas shall be designed and constructed in accordance with Sections R322.2.1 through R322.2.3.

#### R322.2.1 Elevation requirements.

1. Buildings and structures in flood hazard areas not designated as Coastal A Zones shall have the lowest floors elevated to or above the design flood elevation.
2. Buildings and structures in flood hazard areas designated as Coastal A Zones shall have the lowest floors elevated to or above the base flood elevation plus 1 foot (305 mm), or to the design flood elevation, whichever is higher.
3. In areas of shallow flooding (AO Zones), buildings and structures shall have the lowest floor (including *basement*) elevated at least as high above the highest adjacent *grade* as the depth number specified in feet on the FIRM, or at least 2 feet (610 mm) if a depth number is not specified.
4. Basement floors that are below *grade* on all sides shall be elevated to or above the design flood elevation.

**Exception:** Enclosed areas below the design flood elevation, including *basements* whose floors are not below *grade* on all sides, shall meet the requirements of Section R322.2.2.

#### R322.2.2 Enclosed area below design flood elevation.

Enclosed areas, including crawl spaces, that are below the design flood elevation shall:

1. Be used solely for parking of vehicles, building access or storage.
2. Be provided with flood openings that meet the following criteria:
  - 2.1. There shall be a minimum of two openings on different sides of each enclosed area; if a building has more than one enclosed area below the design flood elevation, each area shall have openings on exterior walls.
  - 2.2. The total net area of all openings shall be at least 1 square inch (645 mm<sup>2</sup>) for each square foot (0.093 m<sup>2</sup>) of enclosed area, or the openings shall be designed and the *construction documents* shall include a statement by a registered *design professional* that the design of the openings will provide for equalization of hydrostatic flood forces on exterior walls by allowing for the automatic entry and exit of floodwaters as specified in Section 2.6.2.2 of ASCE 24.
  - 2.3. The bottom of each opening shall be 1 foot (305 mm) or less above the adjacent ground level.
  - 2.4. Openings shall be not less than 3 inches (76 mm) in any direction in the plane of the wall.

- 2.5. Any louvers, screens or other opening covers shall allow the automatic flow of floodwaters into and out of the enclosed area.
- 2.6. Openings installed in doors and windows, that meet requirements 2.1 through 2.5, are acceptable; however, doors and windows without installed openings do not meet the requirements of this section.

**R322.2.3 Foundation design and construction.** Foundation walls for all buildings and structures erected in flood hazard areas shall meet the requirements of Chapter 4.

**Exception:** Unless designed in accordance with Section R404:

- 1. The unsupported height of 6-inch (152 mm) plain masonry walls shall be no more than 3 feet (914 mm).
- 2. The unsupported height of 8-inch (203 mm) plain masonry walls shall be no more than 4 feet (1219 mm).
- 3. The unsupported height of 8-inch (203 mm) reinforced masonry walls shall be no more than 8 feet (2438 mm).

For the purpose of this exception, unsupported height is the distance from the finished *grade* of the under-floor space and the top of the wall.

**R322.2.4 Pools in flood hazard areas.** Pools that are located in flood hazard areas established by Table R301.2(1), including above-ground pools, on-ground pools, and in-ground pools that involve placement of fill, shall comply with Sections R322.2.4.1 or R322.2.4.2.

**Exception:** Pools located in riverine flood hazard areas which are outside of designated floodways.

**R322.2.4.1 Pools located in designated floodways.** Where pools are located in designated floodways, documentation shall be submitted to the building official, which demonstrates that the construction of the pool will not increase the design flood elevation at any point within the jurisdiction.

**R322.2.4.2 Pools located where floodways have not been designated.** Where pools are located where design flood elevations are specified but floodways have not been designated, the applicant shall provide a floodway analysis that demonstrates that the proposed pool will not increase the design flood elevation more than 1 foot (305 mm) at any point within the jurisdiction.

**R322.3 Coastal high-hazard areas (including V Zones).** Areas that have been determined to be subject to wave heights in excess of 3 feet (914 mm) or subject to high-velocity wave action or wave-induced erosion shall be designated as coastal high-hazard areas. Buildings and structures constructed in whole or in part in coastal high-hazard areas shall be designed and constructed in accordance with Sections R322.3.1 through R322.3.6.

**R322.3.1 Location and site preparation.**

- 1. New buildings and buildings that are determined to be substantially improved pursuant to the *Florida Building Code, Existing Building* shall be located landward of the reach of mean high tide.
- 2. For any alteration of sand dunes and mangrove stands the *building official* shall require submission of an engineering analysis which demonstrates that the proposed *alteration* will not increase the potential for flood damage.

**R322.3.2 Elevation requirements.**

- 1. All buildings and structures erected within coastal high hazard areas shall be elevated so that the lowest portion of all structural members supporting the lowest floor, with the exception of mat or raft foundations, piling, pile caps, columns, grade beams and bracing, is:
  - 1.1. Located at or above the design flood elevation, if the lowest horizontal structural member is oriented parallel to the direction of wave approach, where parallel shall mean less than or equal to 20 degrees (0.35 rad) from the direction of approach, or
  - 1.2. Located at the base flood elevation plus 1 foot (305 mm), or the design flood elevation, whichever is higher, if the lowest horizontal structural member is oriented perpendicular to the direction of wave approach, where perpendicular shall mean greater than 20 degrees (0.35 rad) from the direction of approach.
- 2. Basement floors that are below *grade* on all sides are prohibited.
- 3. The use of fill for structural support is prohibited.
- 4. Minor grading, and the placement of minor quantities of fill, shall be permitted for landscaping and for drainage purposes under and around buildings and for support of parking slabs, pool decks, patios and walkways.

**Exception:** Walls and partitions enclosing areas below the design flood elevation shall meet the requirements of Sections R322.3.4 and R322.3.5.

**R322.3.3 Foundations.** Buildings and structures erected in coastal high-hazard areas shall be supported on pilings or columns and shall be adequately anchored to those pilings or columns. The space below the elevated building shall be either free of obstruction or, if enclosed with walls, the walls shall meet the requirements of Section R322.3.4. Pilings shall have adequate soil penetrations to resist the combined wave and wind loads (lateral and uplift). Water loading values used shall be those associated with the design flood. Wind loading values shall be those required by this code. Pile embedment shall include consideration of decreased resistance capacity caused by scour of soil strata surrounding the piling. Pile systems design and installation shall be certified in accordance with Section R322.3.6. Mat, raft or other foundations that support columns shall not be permitted where soil investigations that are required in accordance

with Section R401.4 indicate that soil material under the mat, raft or other foundation is subject to scour or erosion from wave-velocity flow conditions. Slabs, pools, pool decks and walkways shall be located and constructed to be structurally independent of buildings and structures and their foundations to prevent transfer of flood loads to the buildings and structures during conditions of flooding, scour or erosion from wave-velocity flow conditions, unless the buildings and structures and their foundation are designed to resist the additional flood load.

**R322.3.3.1 Pools.** Pools in coastal high-hazard areas shall be designed and constructed in conformance with ASCE 24.

**R322.3.4 Walls below design flood elevation.** Walls and partitions are permitted below the elevated floor, provided that such walls and partitions are not part of the structural support of the building or structure and:

1. Electrical, mechanical, and plumbing system components are not to be mounted on or penetrate through walls that are designed to break away under flood loads; and
2. Are constructed with insect screening or open lattice; or
3. Are designed to break away or collapse without causing collapse, displacement or other structural damage to the elevated portion of the building or supporting foundation system. Such walls, framing and connections shall have a design safe loading resistance of not less than 10 (479 Pa) and no more than 20 pounds per square foot (958 Pa); or
4. Where wind loading values of this code exceed 20 pounds per square foot (958 Pa), the *construction documents* shall include documentation prepared and sealed by a registered *design professional* that:
  - 4.1. The walls and partitions below the design flood elevation have been designed to collapse from a water load less than that which would occur during the design flood.
  - 4.2. The elevated portion of the building and supporting foundation system have been designed to withstand the effects of wind and flood loads acting simultaneously on all building components (structural and nonstructural). Water loading values used shall be those associated with the design flood. Wind loading values shall be those required by this code.

**R322.3.5 Enclosed areas below design flood elevation.** Enclosed areas below the design flood elevation shall be used solely for parking of vehicles, building access or storage.

**R322.3.6 Construction documents.** The *construction documents* shall include documentation that is prepared and sealed by a registered *design professional* that the design and methods of construction to be used meet the applicable criteria of this section.

## SECTION R323 STORM SHELTERS

**R323.1 General.** This section applies to the construction of storm shelters when constructed as separate detached buildings or when constructed as safe rooms within buildings for the purpose of providing safe refuge from storms that produce high winds, such as tornados and hurricanes. In addition to other applicable requirements in this code, storm shelters shall be constructed in accordance with ICC/NSSA-500.

## SECTION 324 AIRPORT NOISE

**R324.1 Airport noise study guidelines.** The Aviation Safety and Noise Abatement Act of 1979 14 CFR Part 150 (US Department of Transportation) including revisions through January 2005 and hereby adopted as a guideline for establishing airport noise control. When required by a local government by local ordinance to provide noise attenuation in a new structure or addition to an existing structure near an airport in the area of the local government, the applicant must provide either:

1. A testing certificate from an accredited noise testing lab that a new structure or addition to existing structure built to the submitted engineering plans will achieve an average minimum dBA reduction equal to or greater than the reduction required;
2. An engineering judgement signed and sealed by an engineer licensed in the State of Florida that the structure or addition built to the submitted engineering plans will achieve an average minimum dBA reduction equal to or greater than the reduction required; or
3. Plans using the standards contained in "Guidelines for Sound Insulation of Residences Exposed to Aircraft Operations" prepared for the Department of the Navy by Wyle Research and Consulting, Arlington, Virginia, April 2005 on file with the Florida Building Commission.